

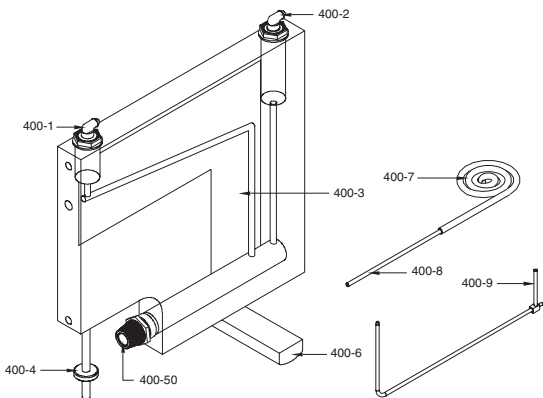

# Series 400 Air Velocity Meter

## Operating Instructions and Parts List



- |          |  |           |  |
|----------|--|-----------|--|
| (400-1)  | Gage body, 5", 10" or 23" range              | (400-7)   | Rubber tubing, 3/14" I.D., 9 ft.                     |
| (400-2)  | Molded Nylon Connector — Rapid shut off type | (400-8)   | Gage body, 5", 10" or 23"                            |
| (400-3)  | Scale, 5", 10" or 23" range                  | (400-9)   | Pitot tube, 8" or 18"                                |
| (400-4)  | Leveling screw                               | (400-100) | 3/4 oz. bottle red gage oil (not shown)              |
| (400-50) | Oil level adjustment assembly range          | (400-11)  | Magneclips, magnetic gage mounting clips (not shown) |
| (400-6)  | Gage stand, washer and screw                 | (400-12)  | Carrying case (not shown)                            |

1. Remove gage from case. Set up in vertical position using (a) gage stand and leveling screw or (b) Magneclips on a vertical steel surface.
2. Turn connectors counterclockwise 1/2 to 3/4 turns, thus venting gage to atmosphere.
3. Center bubble between cross hairs on spirit level with leveling screw or by shifting gage position.
4. Turn oil level adjustment knob to set the meniscus of the oil column at zero, as in sketch.



Align oil meniscus and the reflected image to eliminate parallax error.

5. Add or remove oil as necessary.
6. Use left hand gage connection for plus (above atmospheric) pressures. Connect to right side for minus (below atmospheric) pressures. Connect to both sides for differential pressures, as with a pitot tube.

### CAUTION:

Use only Dwyer gage oil. Clean with mild soap and water only. Other fluids, solvents or cleaning agents may damage the gage.

**DWYER INSTRUMENTS INC.**  
MICHIGAN CITY, IN 46360 U.S.A.

## AIR VELOCITY

The total pressure of an air stream flowing in a duct is the sum of the static or bursting pressure exerted upon the sidewalls of the duct and the impact or velocity pressure of the moving air. Through the use of a pitot tube connected differentially to a manometer, the velocity pressure alone is indicated and the corresponding air velocity determined.

For accuracy of plus or minus 2%, as in laboratory applications, extreme care is required and the following precautions should be observed:

1. Duct diameter 4" (8.64 mm) or greater.
2. Make an accurate traverse per sketch at right and average the readings.
3. Provide smooth, straight duct sections 10 diameters in length both upstream and downstream from the pitot tube.
4. Provide an egg crate type straightener upstream from the pitot tube.

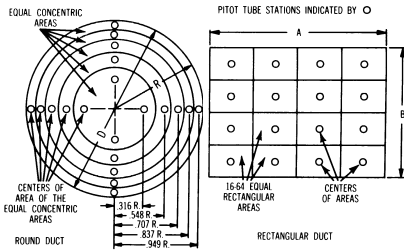

In making an air velocity check, select a location as suggested above, connect tubing leads from both pitot tube connections to the manometer and insert in the duct with the tip directed into the air stream. If the manometer shows a minus indication reverse the tubes. With a direct reading manometer, air velocities will now be shown in feet per minute. In other types, the manometer will read velocity pressure in inches of water and the corresponding velocity will be found from the curves in Bulletin H-11. If circumstances do not permit an accurate traverse, center the pitot tube in the duct, determine the center velocity and multiply by a factor of .9 for the approximate average velocity. Field tests run in this manner should be accurate within plus or minus 5%.

The velocity indicated is for dry air at 70°F (21.3°C), 29.9" Barometric Pressure and a resulting density of .075= /cu. ft. For air at a temperature other than 70°F, refer to the curves in Bulletin H-11. For other variations from these conditions, corrections may be based upon the following data:

$$\text{Air Velocity} = 1096.7 \sqrt{\frac{P_v}{D}}$$

where  $P_v$  = velocity pressure in inches of water  
 $D$  = Air density in lbs/cu. ft.

$$\text{Air Density} = 1.325 \times \frac{P_b}{T}$$

where  $P_b$  = Barometric Pressure in inches of mercury  
 $T$  = Absolute Temperature (indicated temperature plus 460)

Flow in cu. ft. per min. = Duct area in square feet x air velocity in ft. per minute.

## STATIC PRESSURE

In checking inlet and discharge fan and blower pressures, balancing ventilation and dust collection systems, checking exhaust systems and similar installations, air velocities above 700 ft. per min. (12.81 kms/hr) can cause an appreciable error. It is recommended that the static connection of the pitot tube or a static pressure tip be used. In using the static pressure tip or pitot tube, the tip should be directed into the air stream. For permanent installation, static pressure tips are recommended. If not available, make connections, enter the duct perpendicular to the air stream and finish off flush and smooth on the inside.

## FURNACE DRAFT

Connect the terminal tube to the minus pressure gage opening and insert it into the combustion chamber for over fire draft reading. If a drilled port is not available insert through fire door but seal the crack. For last pass or smoke pipe draft, connect into the breeching on the furnace side of any draft control or damper. To determine draft loss through the furnace, make connection as indicated for smoke pipe draft and add a second tube, connecting the manometer differentially to the combustion chamber.

## AIR FILTER TEST

To determine the pressure drop across an air filter, connect the manometer differentially with one tubing from the downstream or blower side of the filter to the right hand or minus pressure gage connection. Run the second tubing from the upstream side of the filter to the other gage connection. Use static pressure tips if available, with the tips directed into the air stream, to eliminate possibility of error due to air velocity. Read the pressure drop across the filter in inches of water and follow the filter manufacturer's recommendations for filter cleaning or replacement.