



Series
DS

In-Line Flow Sensors

Use with the Dwyer Differential Pressure Gages or Transmitters

Air Velocity

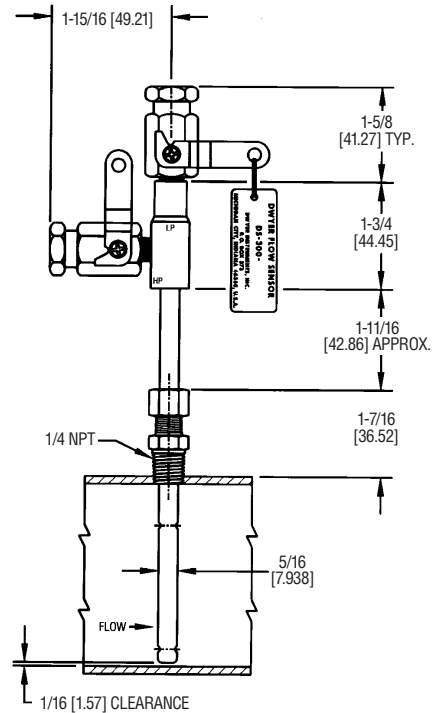
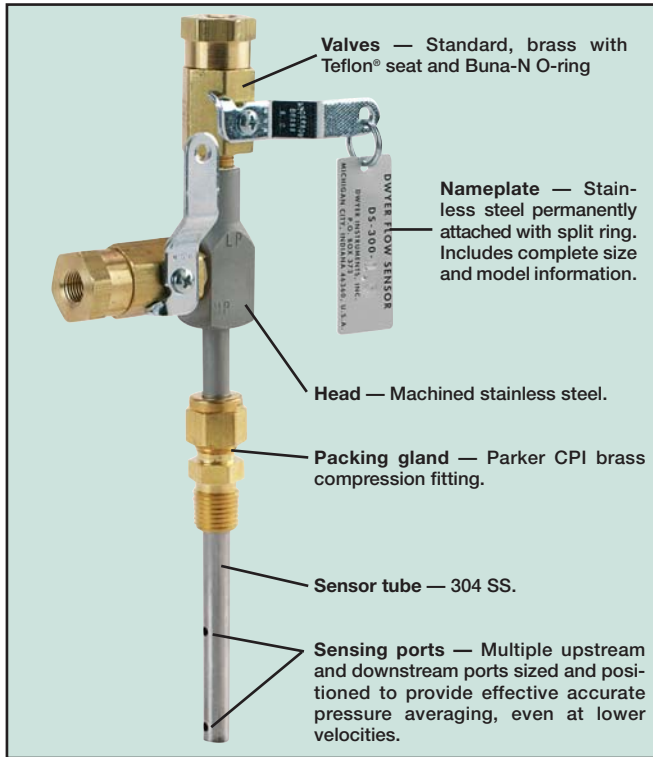

Dwyer Flow Sensors are averaging Pitot tubes that provide accurate and convenient flow rate sensing for schedule 40 pipe. When purchased with a Dwyer Capsuhelic® differential pressure gage of appropriate range, the result is a flow indicating system delivered off the shelf at an economical price.

Pitot tubes have been used in flow measurement for years. Conventional pitot tubes sense velocity pressure at only one point in the flowing stream. Therefore, a series of measurements must be taken across the stream to obtain a meaningful average flow rate. The Dwyer flow sensor eliminates the need for “traversing” the flowing stream because of its multiple sensing points and built-in averaging capability.

Dwyer Series DS-300 flow sensors are designed to be inserted in the pipeline through a compression fitting. They are furnished with instrument shut-off valves on both pressure connections. Valves are fitted with 1/8" female NPT connections. Accessories include adapters with 1/4" SAE 45° flared ends compatible with hoses supplied with the Model A-471 Portable Capsuhelic® kit. Standard valves are rated at 200 psig (13.7 bar) and 200°F (93.3°C). Where valves are not required, they can be omitted at reduced cost. Series DS-300 flow sensors are available for pipe sizes from 1" to 10".

DS-400 Averaging Flow Sensors are quality constructed from extra strong 3/4" dia. stainless steel to resist increased forces encountered at higher flow rates with both air and water. This extra strength also allows them to be made in longer insertion lengths up to 24 inches (61 cm). All models include convenient and quick-acting quarter-turn ball valves to isolate the sensor for zeroing. Process connections to the valve assembly are 1/8" female NPT. A pair of 1/8" NPT × 1/4" SAE 45° flared adapters are included, compatible with hoses used in the Model A-471 Portable Capsuhelic® Gage Kit. Supplied solid brass mounting adapter has a 3/4" dia. compression fitting to lock in required insertion length and a 3/4" male NPT thread for mounting in a thread-let (not included).

Select model with suffix which matches pipe size

- DS-300-1"
- DS-300-1 1/4"
- DS-300-1 1/2"
- DS-300-2"
- DS-300-2 1/2"
- DS-300-3"
- DS-300-4"
- DS-300-6"
- DS-300-8"
- DS-300-10"

- DS-400-6"
- DS-400-8"
- DS-400-10"
- DS-400-12"
- DS-400-14"
- DS-400-16"
- DS-400-18"
- DS-400-20"
- DS-400-24"

Options and Accessories

A-160 Thredolet, 3/8" NPT, forged steel, 3000 psi

A-161 Brass Bushing, 1/4" x 3/8"

(DS-300) To order, add suffix -LVdeduct

Ⓢ Items subject to Schedule B discounts

How To Order

Merely determine the pipe size into which the flow sensor will be mounted and designate the size as a suffix to Model DS-300. For example, a flow sensor to be mounted in a 2" pipe would be a Model No. DS-300-2".

For non-critical water and air flow monitoring applications, the chart below can be utilized for ordering a stock Capsuhelic® differential pressure gage for use with the DS-300 flow sensor. Simply locate the maximum flow rate for the media being measured under the appropriate pipe size and read the Capsuhelic® gage range in inches of water column to the left. The DS-300 sensor is supplied with installation and operating instructions, Bulletin F-50. It also includes complete flow conversion information for the three media conditions shown in the chart below. This information enables the user to create a complete differential pressure to flow rate conversion table for the sensor and differential pressure gage employed. Both the Dwyer Capsuhelic® gage and flow sensor feature excellent repeatability so, once the desired flow rate is determined, deviation from that flow in quantitative measure can be easily determined. You may wish to order the adjustable signal flag option for the Capsuhelic® gage to provide an easily identified reference point for the proper flow.

Capsuhelic® gages with special ranges and/or direct reading scales in appropriate flow units are available on special order for more critical applications. Customer supplied data for the full scale flow (quantity and units) is required along with the differential pressure reading at that full flow figure. Prior to ordering a special Capsuhelic® differential pressure gage for flow read-out, we recommend you request Bulletin F-50 to obtain complete data on converting flow rates of various media to the sensor differential pressure output. With this bulletin and after making a few simple calculations, the exact range gage required can easily be determined.

Large 3/4 Inch Diameter for Extra Strength in Lengths to 24 Inches

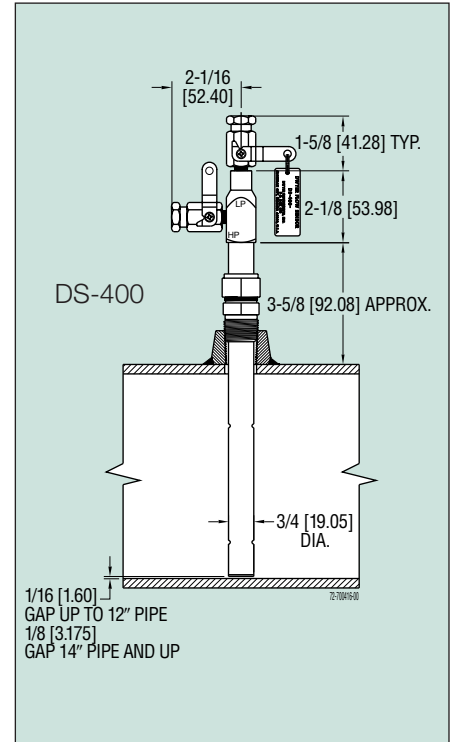

Air Velocity

GAGE RANGE (IN. W.C.)	MEDIA @ 70°F	FULL RANGE FLOWS BY PIPE SIZE (APPROXIMATE)									
		1"	1 1/4"	1 1/2"	2"	2 1/2"	3"	4"	6"	8"	10"
2	Water (GPM)	4.8	8.3	11.5	20.5	30	49	86	205	350	560
	Air @ 14.7 PSIA (SCFM)	19.0	33.0	42.0	65.0	113	183	330	760	1340	2130
	Air @ 100 PSIG (SCFM)	50.0	90.5	120.0	210.0	325	510	920	2050	3600	6000
5	Water (GPM)	7.7	14.0	18.0	34.0	47	78	138	320	560	890
	Air @ 14.7 PSIA (SCFM)	30.0	51.0	66.0	118.0	178	289	510	1200	2150	3400
	Air @ 100 PSIG (SCFM)	83.0	142.0	190.0	340.0	610	820	1600	3300	5700	10000
10	Water (GPM)	11.0	19.0	25.5	45.5	67	110	195	450	800	1260
	Air @ 14.7 PSIA (SCFM)	41.0	72.0	93.0	163.0	250	410	725	1690	3040	4860
	Air @ 100 PSIG (SCFM)	120.0	205.0	275.0	470.0	740	1100	2000	4600	8100	15000
25	Water (GPM)	18.0	32.0	40.5	72.0	108	173	310	720	1250	2000
	Air @ 14.7 PSIA (SCFM)	63.0	112.0	155.0	255.0	390	640	1130	2630	4860	7700
	Air @ 100 PSIG (SCFM)	185.0	325.0	430.0	760.0	1200	1800	3300	7200	13000	22000
50	Water (GPM)	25.0	44.0	57.5	100.0	152	247	435	1000	1800	
	Air @ 14.7 PSIA (SCFM)	90.0	161.0	205.0	360.0	560	900	1600	3700	6400	
	Air @ 100 PSIG (SCFM)	260.0	460.0	620.0	1050.0	1700	2600	4600	10000	18500	
100	Water (GPM)	36.5	62.0	82.0	142.0	220	350	620	1500		
	Air @ 14.7 PSIA (SCFM)	135.0	230.0	300.0	505.0	800	1290	2290	5000		
	Air @ 100 PSIG (SCFM)	370.0	660.0	870.0	1500.0	2300	3600	6500	15000		

Model A-471 Portable Kit

The Dwyer Series 4000 Capsuhelic® differential pressure gage is ideally suited for use as a read-out device with the DS-300 Flow Sensors. The gage may be used on system pressures of up to 500 psig even when the flow sensor differential pressure to be read is less than 0.5" w.c. With accuracy of ±3% of full scale, the Capsuhelic® gage can be used in ambient temperatures from 32 to 200°F (0 to 93.3°C). Zero and range adjustments are made from outside the gage. The standard gage with a die cast aluminum housing can be used with the flow sensor for air or oil applications. For water flow measurements, the optional forged brass housing should be specified. The Capsuhelic® gage may be panel or surface mounted and permanently plumbed to the flow sensor if desired. The optional A-610 pipe mounting bracket allows the gage to be easily attached to any 1/4" - 2" horizontal or vertical pipe.

For portable operation, the A-471 Capsuhelic® Portable Gage Kit is available complete with tough polypropylene carrying case, mounting bracket, 3-way manifold valve, two 10' high pressure hoses, and all necessary fittings. See pages 6 and 7 for complete information on the Capsuhelic® gage.



CAPSULHELIC® GAGE SHOWN INSTALLED IN A-471 PORTABLE KIT