

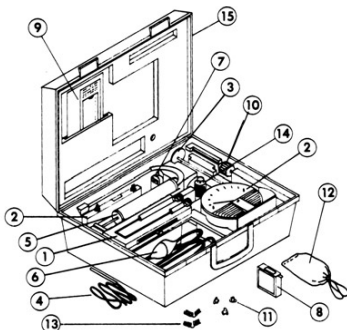

No. 1200 Combustion Test Kit Parts List



1. No. 1101 CO₂ Indicator, range 0 - 16%
2. Draft Gage; one included
1200- A
No. 171, range 0 - .25 in. w.c. (Std. English)
No. M-171, range 0 - .6.6 mm w.c. (Std. Metric)
1200 -B
2000-00-AV Magnehelic® gage, dual scale, range
0 - 25 in. w.c. 300 - 2000 FPM (English)
2000-10MM Magnehelic gage, range 0 - 10 mm
w.c. (Metric)
3. Stack Thermometer; one included
No. A-503, Dial Type 200-1000°F (Std. English)
No. A-504, Dial Type 100-500°C (Std. Metric)
4. Rubber Draft Gage Tubing, 9 ft. (Cat. No. A-201)
5. No. 920 Smoke Gage Pump & Tubing Assembly
6. CO₂ Indicator Aspirator Bulb, Filter & Tubing
Assembly
7. Gage Oil, .826 Sp. Gr., ¾ Oz. (Cat. No. A-101)
8. Smoke Gage Sample Paper (Cat. No. A-387-1)
9. Operating Instructions, Parts List, Combustion
Efficiency Slide Rule, Smoke Chart
10. Awl to pierce smoke pipe for thermometer and
sampling tube (Cat. No. A-388)
11. Smoke Pipe Hole Plugs for 5/16" Hole, pkg. of
20 (Cat. No. A-386)
12. Bag — Filter Wool
13. Thermometer and Terminal Tube Holder (Cat. No.
A-357).
14. Red Absorbent Solution for CO₂ Indicator
15. Plastic carrying case

For replacement parts or repair, write:

DWYER INSTRUMENTS, INC.
P.O. BOX 373
MICHIGAN CITY, IN 46361, U.S.A

Phone: 219/879-8000
Fax: 219/872-9057
www.dwyer-inst.com
e-mail: info@dwyer-inst.com

EIGHT TIPS FOR EFFICIENT OIL BURNER OPERATION

1. Check the load on the system as a whole.
2. Be sure you know what is required in BTU's per hour of the system and what is demanded for correct system control.
3. A general figure of 140,000 BTU per gallon of oil is used in computing input. Multiply this figure by the per cent of efficiency of the system to determine the BTU applied to it. Don't split hairs for you are working with approximate figures.
4. Try to obtain as high as possible a CO₂ reading. Yet do not forget that it may be necessary to sacrifice 1 or 2% CO₂ to make allowances for cold starts and those few poor-draft days.
5. Remember that soot formed on cool surfaces during the starting periods causes more inefficiency by "insulating" the heat from the system and thereby causing a longer operating period with a corresponding increased stack loss.
6. What is CO₂? This is the chemical symbol for carbon dioxide, the most significant component of the mixture of flue gases. Carbon dioxide is formed by the complete burning of the carbon of the fuel. When there is not enough air for complete burning, a gas is formed called carbon monoxide (CO). When CO is formed, much less heat produced than when CO₂ is formed.
7. Too high a CO₂ reading is always a "dirty" flame, usually producing soot. Keep the flame clean! Smoke is a warning of too high a CO₂ reading. There is no visible warning of too low a CO₂ reading. Always use your smoke tester!
8. Samples of gases must always be taken where the gases leave the system and ahead of dampers, diverters or barometric draft controls.