

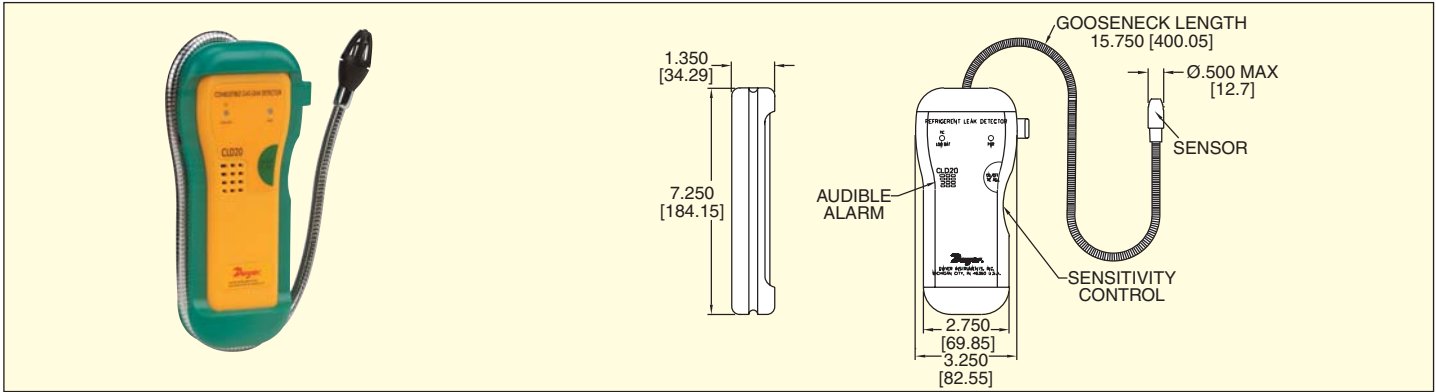

Model
CLD20

Combustible Leak Detector

Adjustable Tick Rate, <1 Second Response



Quickly locate leaks of combustible gases with the Model CLD20 Combustible Leak Detector. Unit provides accurate detection of Methane, Butane, Ammonia, Ethylene Oxide, Alcohols, Industrial Solvents and other combustible or toxic gases. Adjustable tick rate accelerates as the sensor tip approaches a leak and can be re-zeroed to pinpoint the exact location of the leak. The Model CLD20 offers visual LED indication of leak level and automatically recalibrates when turned off and on. Flexible gooseneck and small sensor head allows use in tight, difficult to reach areas.

Model No. CLD20 Combustible Leak Detector

SPECIFICATIONS

Sensitivity: 50 ppm.

Response Time: Less than 1 second.

Sensor: Solid state semiconductor.

Ambient Operating Temperature/RH: 32 to 104°F (0 to 40°C), 0 to 80% RH (non-condensing).

Power Requirements: One 9V alkaline battery.

Battery Life: Approximately 10 hours of continuous usage.

Warm-up Time: 10 seconds.

Pre-programmed fuels: (partial listing) Methane, Natural gas, Ammonia, Hydrogen, Butane, Propane, Acetone, Ethylene Oxide, Halon, Hydrogen Sulphide, Alcohol, Jet Fuel, Lacquer, and Thinners.

Alarm Settings: Audio: adjustable tick rate 75dB @ 1 ft (30 cm), Visual: flashing LED.

Probe: 16" (40 cm) length, flexible gooseneck.

Dimensions: 7.3"H x 3.4"W x 1.4"D (18.5 x 8.5 x 3.4 cm).

Weight: 18 oz (500 g).

Agency Approvals: CE.



Model
RLD1

Refrigerant Leak Detector

Audio and Visual Indication, Flexible Gooseneck Design

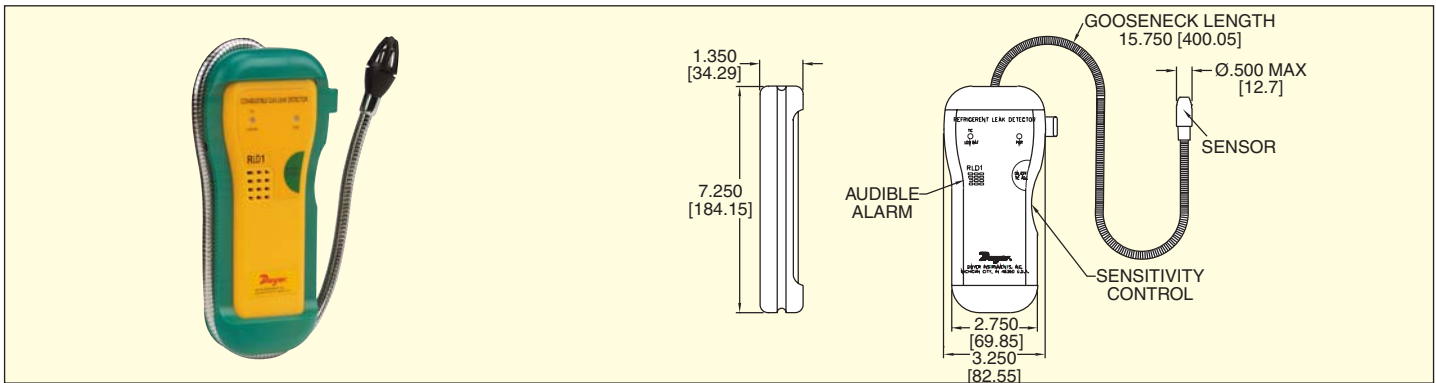

Detect and pinpoint even small leaks of refrigerant gases using the Model RLD1 Refrigerant Leak Detector. The RLD1 is effective in detecting existing refrigerants including HFC, HCFC, CFC, SF6, R134a, and R123. Unit features thumbwheel operation to increase sensitivity and audio and visual indication. An increasing tick rate sounds as a leak is pinpointed and the red indication light flashes more rapidly. The flexible gooseneck probe is ideal for hard to reach areas. Use the model RLD1 in domestic and commercial refrigeration systems, automotive, air conditioning, and quality control testing environments.

Model No. RLD1 Refrigerant Leak Detector

SPECIFICATIONS

Sensitivity: 0.4 oz/year (11 gm/year) R134a.

Response Time: Less than 1 second.

Sensor: Advanced ionization detection.

Ambient Operating Temperature/RH: 32 to 104°F (0 to 40°C), 0 to 80% RH (non-condensing).

Power Requirements: One 9V alkaline battery.

Battery Life: Approximately 16 hours.

Warm-up Time: 10 seconds.

Pre-programmed gases: (partial listing) CFCs: R11, R12, R13, HCFCs: R22, R502, R500, HFCs: R134a, R123, R125, R23, and other halogen based compounds.

Alarm Settings: Audio: adjustable tick rate, Visual: flashing LED.

Probe: 15-3/4" (40 cm) length, flexible gooseneck.

Dimensions: 7.3"H x 3.4"W x 1.4"D (18.5 x 8.5 x 3.4 cm).

Weight: 18 oz (500 g).

Agency Approvals: CE.