

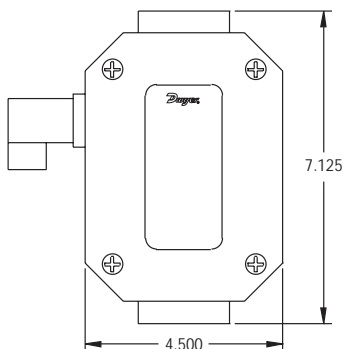

Series HFT Flow Transmitters

Specifications – Operating Instructions



Series HFT Flow Transmitters are typically used to transmit a signal proportional to flow rate to a process control computer, a PLC, a recorder, or a panel-mount display. The Flow Transmitters are used as the primary input device to record flow rates through hydraulic and pneumatic systems. The universal output transmitter circuit employed by the Series HFT Flow Transmitter is capable of producing output signals of 4-20mA, 0-5 VDC, and 0-2000 Hz square wave pulse. A 1-5 VDC signal may be obtained from the 4-20 mA signal by placing a 249 Ω resistor in parallel with the receiver.

Note: Refer to Series HF In-Line Flow Monitor, Bulletin F-55, "Installation and Operating Instructions" for installation, operation, and cleaning instructions for the basic flow monitor cartridge (included). The following instructions are specifically for the Series HFT circuitry for transmitting a proportional output signal.

SPECIFICATIONS

Service: Compatible gases or liquids.

Wetted Materials: Body: Aluminum, brass or 304 SS; Seals: Buna-N or Fluoroelastomer; Magnet: PTFE coated Alnico; Other internal parts: 304 SS.

Viscosity Limit: 500 SSU.

Accuracy: $\pm 4\%$ FS over entire range; $\pm 2.5\%$ over center third of the measuring range.

Repeatability: $\pm 1\%$ of full scale.

Response Time: <100 msec.

Output Signal: 4-20 mA; 0-5 V; 1-5 V.

Temperature Limits: 240°F (116°C).

Pressure Limits: See Chart.

Power Requirements: 12-35 VDC.

Enclosure Rating: NEMA 4X (IP65).

Shipping Weight: 1/4 to 1/2" female NPT Models: 3 lb (1.4 kg); 3/4 to 1" female NPT Models: 4.5 lb (2.0 kg); 1-1/2" female NPT Models: 12 lb (5.4 kg).

PRESSURE DIFFERENTIAL VS. FLOW RATE

1/4" FEMALE NPT

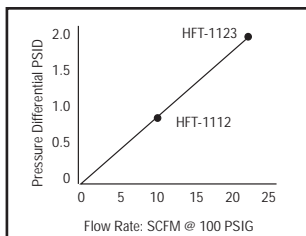

1/2" FEMALE NPT

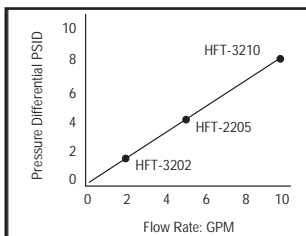

3/4", 1" & 1-1/2" FEMALE NPT

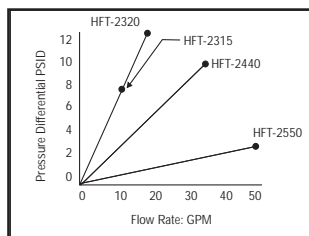

Selecting the Output

The user may choose between reading a 0-2000 Hz square wave pulse, a 0-5 VDC analog signal, or a two-wire 4-20 mA analog signal by connecting to the appropriate pins on the 4-pin Hirschmann® DIN connector and by placing the programmable jumper in the appropriate position for the desired output. An analog 1-5 VDC output may also be obtained by configuring the unit for the two-wire 4-20 mA output and then placing a 249 Ω resistor in parallel with the receiver. The exact output pins and jumper positions that correspond to each output are discussed later in this manual.

Wiring

4-20 mA output connections:

Input Voltage: The supply voltage must be between 12 and 35 VDC. The maximum resistance that may be placed within the current loop is given by the following formula:

$$R_{\max} = 50(V_s - 12)$$

Where:

R_{\max} = the maximum resistance that may be placed in the current loop (Ω).

V_s = the value of the supply voltage (VDC)

Note: Although the signal conditioning circuit does have integral over-current protection, it is recommended that the circuit be protected with a 0.25 amp fuse.

Wiring Instructions:

(Refer to Illustrations 2 & 3)

- 1) Move the programmable jumper on the signal conditioning board into the position closest to the meter's outlet, as shown in Illustration 3.
- 2) Connect the positive DC power source (+12 to +35 VDC) to terminal #1 on the DIN connector.
- 3) Connect terminal #2 of the DIN connector to the positive current input on the receiving device.
- 4) If the power source does not originate from the receiving device, the negative side of the power supply must be connected to the signal ground of the receiving device.

- 5) If the transmitter is operating properly, the green LED on the signal conditioning board will illuminate dimly at zero flow and will increase in intensity as flow increases.

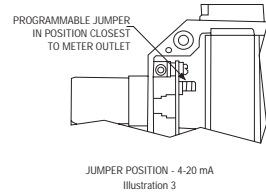
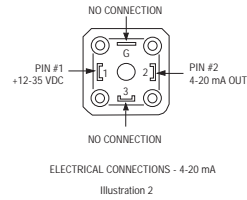

0-5 VDC output connections:

Wiring Instructions:

(Refer to Illustrations 4 & 5)

- 1) Move the programmable jumper on the circuit board into the position closest to the meter's inlet, as shown in Illustration 5.
- 2) Connect the positive voltage source (+12 to +35 VDC) to terminal #1 of the DIN connector.
- 3) Connect terminal #2 of the DIN connector to the negative side of the DC voltage source.
- 4) Connect terminal #3 of the DIN connector to the 0-5 VDC input of the receiving device.
- 5) If the power source does not originate at the receiving device, a wire will need to be connected between the negative side of the voltage source and the signal ground of the receiving device.
- 6) If the transmitter is operating correctly, the green LED on the circuit board will illuminate brightly when power is applied to the unit.

Note: The input impedance (resistance) of the receiving device must not be lower than 100 Ω or non-linearities may result. Lower impedance will not damage the transmitter.

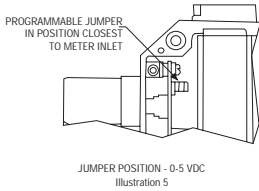
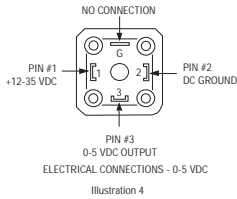

0-2000 Hz pulse output connections:

Wiring Instructions:

(Refer to Illustrations 6 & 7)

- 1) Move the programmable jumper on the circuit board into the position closest to the meter's inlet, as shown in Illustration 7.
- 2) Connect the positive voltage source (+12 to +35 VDC) to terminal #1 of the DIN connector.
- 3) Connect terminal #2 of the DIN connector to the negative side of the DC voltage source.
- 4) Connect the "G" terminal of the DIN connector to the pulse input of the receiving device.
- 5) If the power source does not originate at the receiving device, a wire will need to be connected between the negative side of the voltage source and the signal ground of the receiving device.
- 6) If the transmitter is operating properly, the green LED on the circuit board will illuminate brightly when power is applied to the unit.

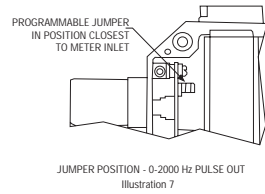
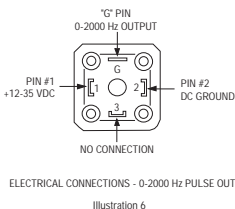

1-5 VDC output connections:

Wiring Instructions:

(Refer to Illustrations 8 & 9)

- 1) Move the programmable jumper on the signal conditioning board into the position closest to the meter's outlet, as shown in Illustration 9.
- 2) Connect the positive voltage (+17 to +35 VDC) to terminal #1 of the DIN connector.
- 3) Connect terminal #2 of the DIN to the 1-5 VDC input of the receiving device.
- 4) Connect one lead of a 249 Ω resistor to Terminal #2 as shown in Illustration 8. Connect to the other lead to signal ground.
- 5) If the power source does not originate at the receiving device, a wire will need to be connected between the negative side of the voltage source and the signal ground of the receiving device.
- 6) If the transmitter is operating properly, the green LED on the circuit board will illuminate dimly at zero flow and will increase in intensity as flow rate increases.

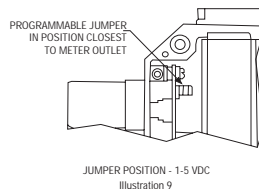
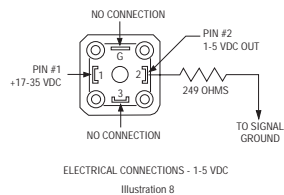

User Adjustments

The 4-20 mA, 0-5V, and 0-2000 Hz square wave outputs on the Flow Transmitter are all factory calibrated. User adjustment should be unnecessary and any adjustment of the potentiometer on the signal conditioning board is **strongly discouraged**. If one of the outputs does fall out of calibration, the following procedure may be used to recalibrate the unit.

- 1) Turn off the flow through the system.
- 2) Connect between +12 and +35 VDC to pin 1 of the DIN connector. Connect terminal 2 of the DIN connector to the negative terminal of the DC supply.
- 3) Move the programmable jumper on the signal conditioning board into the position closest to the sensor's inlet, as shown in Illustrations 5&7.
- 4) Connect the positive terminal of a voltmeter to pin 3 of the DIN connector. Connect the negative terminal to pin 2 of the DIN connector.
- 5) Gradually increase the flow through the system until the flow rate indicated on the printed flow rate scale reaches full-scale (the highest value printed on the scale).
- 6) Adjust the 0-5 VDC Span potentiometer until a reading of 5.00 VDC is obtained on the voltmeter.
- 7) Turn off the flow through the system and remove the voltmeter.
- 8) Move the programmable jumper on the signal conditioning board into the position closest to the sensor's outlet, as shown in illustrations 3 and 9.
- 9) Disconnect pin 1 of the DIN connector from the positive terminal of the DC power supply.
- 10) Connect the positive terminal of an ammeter to the positive terminal of the DC power supply. Connect the negative terminal of the ammeter to pin 1 of the sensor's DIN connector.
- 11) Adjust the 4-20 mA Offset potentiometer (see Illustration 1) until a reading of 4.00 mA is obtained on the ammeter.
- 12) Gradually increase the flow through the system until the flow rate indicated on the printed flow rate scale reaches full-scale (the highest value printed on the scale).
- 13) Adjust the 4-20 mA span potentiometer (see Illustration 1) until a reading of 20.00 mA is obtained on the ammeter.
- 14) Gradually decrease the flow through the system until a value equal to 50% of full-scale is obtained on the sensor's flow rate scale. Verify a reading of between 11.92 and 12.08 mA.

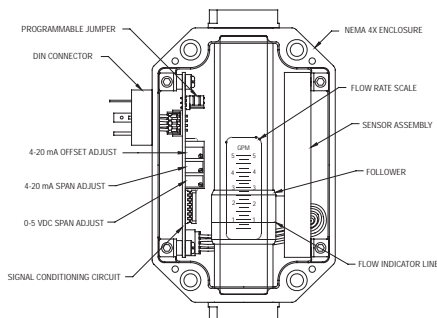

Illustration 10

Troubleshooting Chart

Symptom: The green LED does not illuminate when power is applied.

Remedy:

- 1) Recheck the wiring diagram for the communication protocol that is being used and verify that the wiring is correct.
- 2) Verify that the DC supply that is being used is capable of producing at least 12 VDC.
- 3) Make sure that the cable that is soldered to the DIN connector inside of the sensor enclosure is plugged into the connector opposite to the programmable jumper.

Symptom: The readings obtained from the electronic output do not agree with the readings shown on the printed flow rate scale.

Remedy:

- 1) Make sure that the programmable jumper is in the correct position for the communication protocol that is being used.

Symptom: The green LED illuminates, but no readings are obtained from the sensor's electronic output.

Remedy:

- 1) Re-check the wiring diagram for the communication protocol that is being used and verify that the wiring is correct.
- 2) Make sure that the cable from the sensor assembly is plugged into the connector on the signal conditioning board located near the sensor inlet.

Symptom: When the flow rate in the system changes, the follower and electronic output do not respond.

Remedy:

- 1) Remove the flow sensor from the system and inspect the internals to see if anything has caused them to become jammed. Make sure that the 200 mesh, 74 micron filtration requirement of the flow sensor is being observed.