

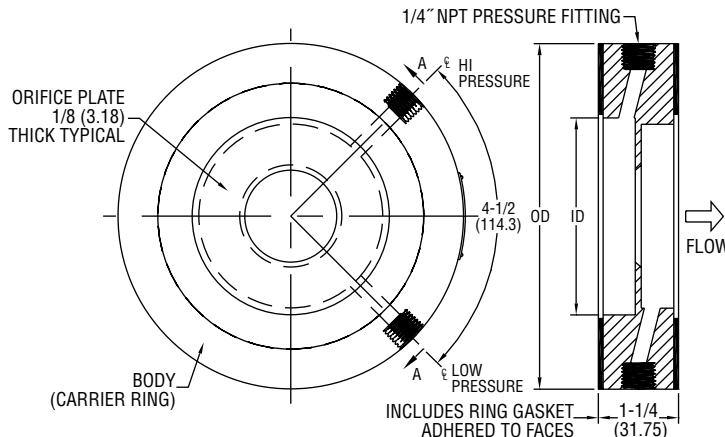

# Series PE Orifice Plate Flow Meter

## Specifications - Installation and Operating Instructions



The Series PE Orifice Plate Flow Meter offers one-piece PVC construction incorporating a unique holder or carrier ring containing metering taps and integral gaskets. Unlike a standard orifice plate, the Series PE is a true primary element including the various components for differential pressure measurement. It was designed for use wherever there is an application for a conventional flow orifice plate. It can also be used in place of other primary differential producers for efficiency and cost effectiveness. The Series PE is available in line sizes from 1/2" to 24" and can be used with air and compatible gases. It meets or exceeds ASME, AGA & ISO standards.

### ACCURACY

The Series PE utilizes the corner tap proportions as defined in ISO 5167. While this code may not be referred to as International Standard until accepted by the ISO Council, the ASME Fluid Meters Research Committee has suggested that the dimensionless coefficient equation developed by the International Standards Organization (ISO) and presented in ISO 5167 is significantly better for the broad spectrum of flow measurement applications throughout process industries.

The coefficient values used in the Series PE bore calculations represent the same confidence level assigned to the flange and radius taps widely accepted in fluid flow measurement.

The accuracy assigned to the coefficient values is ±0.6% full scale for d/D (Beta) values 0.2 to 0.6 and ±0.7% for Beta values 0.7 to 0.75 (i.e. β of 0.7 would have an uncertainty value of ±0.7% full scale).

Accuracy of the differential signal produced by the PE equals that of a properly manufactured and installed flange or radius tap orifice meter.

### MOUNTING

The orifice metering primary shall be suitable for installation between standard ANSI 125#/150# PVC or steel flanges mounted on HDPE, PVC or steel pipe. The unit shall be "self centering" within the bolt circle of the flanges. No alignment of the orifice shall be necessary. Drilling and or tapping of the main or flanges will not be allowed or required. The overall laying length shall be 1.25" including pre-attached ring type 1/8" thick Buna "N" Gaskets. Flange bolts should be 1.25" longer than standard flange bolts.

**Pipe Requirements:** Upstream and downstream pipe requirements are contingent upon two factors: (a) Beta Ratio-ratio of the orifice bore to the pipe ID (d/D); (b) The type of fitting or disturbance upstream of the PE. For most applications, 10 pipe dia. upstream & 5 dia. downstream are sufficient. (5 pipe dia. up and 2 dia. down are acceptable for non-critical applications.)

**Installation Tips:** (a) If possible, do not install a valve upstream if it is going to be throttled. Install on the downstream a minimum of 6 diameters from the PE. (b) The use of straightening vanes is not necessary for most applications.

### SPECIFICATIONS

**Service:** Clean air and compatible gases.

**Wetted Material:** Monolithic (single piece) constructed entirely of gray PVC.

**Accuracy:** ±0.6% full scale flow (Beta = .2-.6) ±0.7% for Beta greater than .6.

**Temperature:** 140°F max (60°C max).

**Pressure:** 150 psi max.

**Head Loss:** 1 - Beta ratio<sup>2</sup> eg: 1 - 0.7<sup>2</sup> = 1 - 0.49 = 51% of the d.p.

**Line Sizes:** 1/2" to 24".

**Process Connections:** 1/4" female NPT.

**Installation:** Standard flange 125#/150# rating.

**Pipe Requirements:** General requirements 10 diameter upstream and 5 diameter downstream.

**Weight:** Varies with line size. See chart.

**Installation:** (a) Insert bolts through bottom half of the flange bolt circle. (b) Slide PE between flanges (make sure arrow on PE faces in the direction of flow). (c) Make sure pressure connections are properly positioned. For horizontal air or gas lines, install with the connections on or above the horizontal center line. They should also be correctly oriented so as to not be blocked by bolts when remainder of bolts are inserted. (d) Add rest of bolts and nuts leaving all bolts loose so PE is free to move. (e) If necessary, the PE can be centered using a steel ruler to measure the total side to side movement and set PE at half way point all around. (f) Lubricate & tighten bolts diametrically alternating to recommend flange torque. (g) Check to insure the PE is installed with the arrow facing in the same direction as flow.

### OVERALL PRESSURE LOSS ACROSS SERIES PE ORIFICES

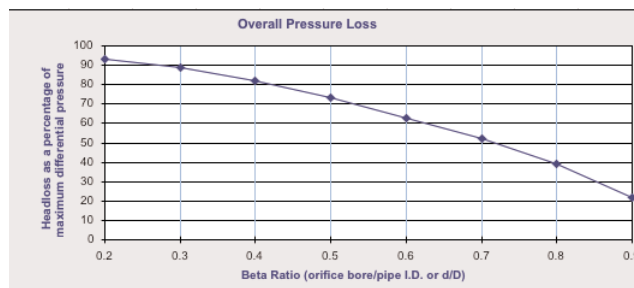

## Series PE Orifice Plate Flow Meter Air Capacity Structure

- Material PVC- Gaskets Buna "N"
- Based on 70°F, 14.7 psia (Base Conditions)
- Beta Value Based on Std Sch pipe I.D.
- 1.25" overall thickness
- Orifice plate thickness is 0.125"

Model #	Weight (lbs)	Line Size	Bore	Beta	Inch d.p. W/C	AIR CAPACITY - Flow in SCFM		
						at 14.7 PSIA (0 PSIG)	at 20 psig	at 100 psig
PE-A-1	1.00	1/2"	0.200"	0.32	20	2.35	3.63	6.61
PE-A-2	1.00	1/2"	0.310"	0.5	100	12.21	19.58	36.37
PE-A-3	1.00	1/2"	0.430"	0.69	200	32.77	56.15	107.47
PE-B-1	1.00	3/4"	0.250"	0.3	20	3.65	5.66	10.3
PE-B-2	1.00	3/4"	0.400"	0.49	100	20.21	32.44	60.26
PE-B-3	1.00	3/4"	0.580"	0.7	200	59.92	102.91	197.2
PE-C-1	1.00	1"	0.300"	0.29	20	5.24	8.11	14.8
PE-C-2	1.00	1"	0.520"	0.49	100	34.2	54.92	102.09
PE-C-3	1.00	1"	0.720"	0.69	200	91.28	156.51	300
PE-D-1	1.00	1.25"	0.400"	0.29	20	9.31	14.41	26.3
PE-D-2	1.00	1.25"	0.700"	0.51	100	62.09	99.75	185.5
PE-D-3	1.00	1.25"	1.00"	0.72	200	180	309.97	595.2
PE-E-1	2.00	1.5"	0.500"	0.31	20	14.57	22.55	41.16
PE-E-2	2.00	1.5"	0.800"	0.5	100	80.82	129.68	241.5
PE-E-3	2.00	1.5"	1.100"	0.68	200	212.18	363.93	697.39
PE-F-1	2.00	2"	0.600"	0.29	20	20.92	32.38	59.13
PE-F-2	2.00	2"	1.000"	0.48	100	125.74	202.03	375.8
PE-F-3	2.00	2"	1.450"	0.7	200	372.09	639.87	1,227.63
PE-G-1	2.00	2.5"	0.750"	0.3	20	32.71	50.64	92.48
PE-G-2	2.00	2.5"	1.250"	0.5	100	197.54	317.58	590.91
PE-G-3	2.00	2.5"	1.750"	0.7	200	543.99	936.56	1,798.86
PE-H-1	2.00	3"	0.920"	0.3	20	49.17	76.13	139.06
PE-H-2	2.00	3"	1.500"	0.49	100	282.9	454.77	846.21
PE-H-3	2.00	3"	2.150"	0.7	200	816.7	1,404.95	2,696.28
PE-J-1	3.00	4"	1.200"	0.3	20	83.58	129.44	236.48
PE-J-2	3.00	4"	2.000"	0.5	100	503.76	810.06	1,507.64
PE-J-3	3.00	4"	2.800"	0.7	200	1,380.03	2,373.02	4,553.68
PE-K-1	3.00	5"	1.500"	0.3	20	130.48	202.11	369.29
PE-K-2	3.00	5"	2.500"	0.5	100	786.23	1,264.42	2,353.51
PE-K-3	3.00	5"	3.500"	0.69	200	2,152.83	3,701.57	7,103.22
PE-L-1	4.00	6"	1.800"	0.3	20	187.86	291	531.75
PE-L-2	4.00	6"	3.000"	0.49	100	1,331.63	1,820.05	3,387.93
PE-L-3	4.00	6"	4.200"	0.69	200	3,097.20	5,325.20	10,219.28
PE-M-1	5.00	8"	2.400"	0.3	20	333.87	517.25	945.28
PE-M-2	5.00	8"	4.000"	0.5	100	2,014.95	3,241.45	6,034.85
PE-M-3	5.00	8"	5.600"	0.7	200	5,532.00	9,525.43	18,290.00
PE-N-1	6.00	10"	3.000"	0.3	20	521.58	808	1,476.77
PE-N-2	6.00	10"	5.000"	0.5	100	3,145.50	5,060.38	9,421.74
PE-N-3	6.00	10"	7.000"	0.7	200	8,626.42	14,846.80	28,506.17
PE-O-1	7.00	12"	3.600"	0.3	20	750.9	1,163.44	2,126.47
PE-O-2	7.00	12"	5.000"	0.5	100	4,530	7,288.16	13,570.33
PE-O-3	7.00	12"	8.400"	0.7	200	12,430.00	21,397.00	41,089.02
PE-P-1	9.00	14"	4.000"	0.3	20	927.14	1,436.59	2,625.81
PE-P-2	9.00	14"	6.600"	0.5	100	6,477.67	8,812.87	16,409.42
PE-P-3	9.00	14"	9.300"	0.7	200	15,251.50	28,262.66	50,427.78
PE-Q-1	10.00	16"	4.500"	0.3	20	1,172.63	1,817.05	3,321.32
PE-Q-2	10.00	16"	7.600"	0.5	100	7,264.58	11,688.26	21,764.08
PE-Q-3	10.00	16"	10.700"	0.7	200	20,179.85	34,749.32	66,737.64
PE-R-1	12.00	18"	5.200"	0.3	20	1,565.79	2,426.34	4,435.12
PE-R-2	12.00	18"	8.600"	0.5	100	9,302.08	14,966.93	27,869.85
PE-R-3	12.00	18"	12.000"	0.7	200	25,299.92	43,535.32	83,587.01
PE-S-1	14.00	20"	5.780"	0.3	20	1,935.37	2,999.11	5,482.22
PE-S-2	14.00	20"	9.600"	0.5	100	11,588.20	18,645.74	34,720.84
PE-S-3	14.00	20"	13.500"	0.7	200	32,115.34	55,303.34	106,215.88
PE-T-1	16.00	24"	7.000"	0.3	20	2,838.14	4,398.25	8,038.99
PE-T-2	16.00	24"	11.700"	0.5	100	17,229.62	27,726.33	51,633.81
PE-T-3	16.00	24"	16.300"	0.7	200	46,810.53	80,610.19	154,823.78

Note: Differential pressure values should be less than 50% of the inlet absolute pressure.

The above curved graph shows pressure loss generated by the Series PE Orifice Plate Flow Meter. For example, a 0.7 Beta Ratio (d/D) would show a loss of 51%. This is also shown on the linear graph area ratio (d/D)<sup>2</sup> = .38 with a loss of 62%.

As a quick check reference, you can use the formula:  
Head loss = 1 - Beta Ratio<sup>2</sup> eg: 1 - 0.7<sup>2</sup> or 1 - 0.49 = 51% of the d.p.  
Source: ASME Research Report on Fluid Meters

Magnehelic® and Capsuhelic® gages from Dwyer read pressure drop across the orifice plates.

For compatible gases a Dwyer Magnehelic® gage may be used to read the differential pressure.

### AIR AND GAS FLOW - CONCENTRIC BORE SCFM BASE CONDITIONS 14.7 psia & 60°F

Conversion formula used to solve for flow rate based on plotting changes in inlet pressure, temperature and/or differential pressure. This formula is designed for use as a "quick check" reference only as the results may differ from calculation values due to rounding, combining of variables, and making certain assumptions in an effort to keep the formula as abbreviated as possible. Equation source *Flow Measurement Engineering Handbook* by Richard Miller.

**Input new differential pressure (h/w) as well as new pressures and/or temperatures using the formula below:**

$$SCFM = \frac{5.9816 \times (d^5) \times (K) \times (Y) \times \sqrt{M} / w \times \sqrt{2.703 \times P_L \times SG} / (460 + T_L)}{2.703 \times 14.7 \times SG / (460 + T_b)}$$

Where:

- 5.9816= physical constant
- d= bore in inches
- K= flow coefficient
- Y= expansion factor
- h/w= differential pressure (inches w/c)
- P<sub>L</sub>= line pressure (psia)
- T<sub>L</sub>= line temperature (°F)
- T<sub>b</sub>= base temperature (°F)
- β= beta ratio (d/D)
- SG= specific gravity at line conditions (air=1.00)
- SH= specific heat ratio cp/cv (air=1.4)
- R<sub>n</sub>=Reynolds number at max flow in pipe

$$K = C \times ((1) / (\sqrt{M} - \beta^4))$$

$$Y = 1 - (.41 + .35\beta^4) \times ((h/w \times .0361) / (P_L \times 1.4))$$

$$C = 0.5959 + 0.0312\beta^{2.1} - 0.1840\beta^8 + 91.71\beta^{2.5} R_n^{-0.75}$$

If Reynolds number (R<sub>n</sub>) is not known, "C" can be estimated as 0.6015. For convenience other factors can be combined to form constants as the equation is developed.

Note: Differential pressure values should be less than 50% of the inlet absolute pressure.

### MAINTENANCE

After final installation of the Series PE Orifice Plate Flow Meter, no routine maintenance is required. A periodic check of system calibration is suggested. With the exception of gasket replacement, these devices are not field repairable and should be returned if repair is needed (field repair should not be attempted and may void warranty). Be sure to include a brief description of the problem plus any relevant application notes. Contact customer service to receive a return goods authorization number before shipping.