

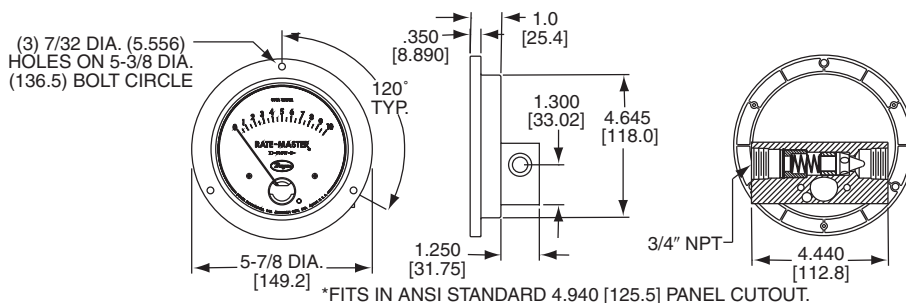

## Series RMV II Rate-Master® Flowmeter

### Specifications - Installation and Operating Instructions



**Dwyer Series RMV II Rate-Master® flowmeters** employ a target-type design combined with a magnetic linkage driving a pointer over a direct reading scale. This unique construction delivers  $\pm 5\%$  of full scale accuracy while enabling leakproof operation at pressures to 3000 psig (206.7 bar). Solid machined brass meter body is ideal for air or water flows. Dial face body fits standard 4-1/2" mounting hole layouts per ANSI B40.1. Inlet and outlet threads are 3/4" female NPT. A 1/2" reducing bushing is available at extra cost. Scales are calibrated for air or water at standard conditions.

#### CALIBRATION

All standard RMV II Rate Master® flowmeters are calibrated at the factory for use with scale in a vertical position and should be installed that way for maximum accuracy.

The unit will normally retain its accuracy tolerance for the useful life of the device. If you want to check the accuracy, do so only with instruments of certified accuracy. Do not attempt to check accuracy with other flowmeters piped in series. Even minor variations in piping and back pressure can cause significant differences in indication. If in doubt, return the flowmeter to the factory for a calibration check.

#### LOCATION

Select a location where the flowmeter can be easily read and ambient temperature will not exceed 200°F (93°C). The mounting surface and piping to the flowmeter should be free from excessive vibration. If pulsing flow or vibration causes excessive pointer oscillation, contact the factory for ways to provide additional dampening.

Because the device operates through a magnetic coupling system, magnetic material located near the brass flow block can affect accuracy. To minimize the effect of outside interference, keep magnetic materials at least 3 inches (7.6 cm) away from unit.

#### SPECIFICATIONS

**Service:** Compatible gases & liquids & oils.

**Wetted Materials:** Brass, 302 SS, sintered barium ferrite, polyacetyl.

**Temperature Limit:** 200°F (93°C).

**Pressure Limit:** 3000 psig (206 bar).

**Pressure Drop:** 0-5 GPM: 3.2 PSID; 0-10 GPM: 5.3 PSID; 0-20 GPM: 10.4 PSID.

**Accuracy:**  $\pm 5\%$  of full scale.

**Size:** Diameter dial face 4.5" (114.3 mm)

**Process Connections:** 3/4" female NPT.

**Weight:** 2 lb, 14 oz (1.3 kg).

#### Inlet Piping

It is a good practice to approach the flowmeter with as few elbows, restrictions and size changes as possible. Inlet piping should be as close to the flowmeter connection size as possible to avoid turbulence which can occur with drastic size changes. The length of inlet piping has little effect on normal pressure fed flowmeters.

For vacuum service the inlet piping should be as short and open as possible to allow operation at or near atmospheric pressure, thus maintaining the accuracy of the device. Note that for vacuum service, any flow control valve must be installed on the discharge side of the flowmeter.

#### Outlet Piping

Piping to the outlet should be at least as large as the inlet connection. For pressure fed flowmeters on air or gas service, the piping should be as large and short as possible. This is so pressure within the device will be at or near atmospheric for maximum accuracy. This is less important on water or liquid flowmeters since the flowing media is generally not compressible and therefore back pressure will not affect the calibration of the instrument.

## Zero Adjustment

Standard Series RMV II flowmeters are calibrated and zeroed at the factory with the scale in a vertical position. If the instrument is used in any other position, it must be rezeroed for maximum accuracy.

To re-zero, insert a small screwdriver blade into the gap of the cover retaining ring near the bottom of the flowmeter face. Pry one end free and completely remove the ring from its groove. Holding one hand on the cover, turn the unit over until cover drops free into your palm. Be careful to avoid scratching the cover.

In the lower right area of the scale there is a 1/8" dia. knurled knob which is used to adjust the zero reading. Turn it clockwise to move pointer upscale or counter-clockwise to move it downscale. Make these adjustments with the flowmeter in the position in which it will be mounted. If the pointer moves downscale while turning the knob clockwise, continue to turn the knob clockwise until upscale pointer movement occurs. Re-zero as described above.

After adjustment, make sure the O-ring is properly positioned in its groove and replace the cover. Next, replace the retaining ring. Start at one end and carefully press it into place working in a counter-clockwise direction. If ring is difficult to replace by hand, it may be necessary to use a small screwdriver blade to guide it in. Be careful to avoid scratching the cover.

## In-Line Mounting

RMV II flowmeters can be installed in-line supported only by the piping. Be sure to use a wrench on the brass meter body when tightening to avoid application of torque to the plastic dial housing. Permanent damage can result.

## Flush Mounting

To flush panel mount, cut a 4.94" (125 mm) mounting hole and drill three 7/32" (5.56 mm) bolt holes on a 5-3/8" (137 mm) circle as shown in the drawing on the front of this bulletin. Attach flowmeter with 3/16" bolts of appropriate length.

## OPERATION

If flowing media is likely to be dirty, install a 50 micron filter upstream from the flowmeter. Once all connections are complete, introduce flow slowly to avoid possible damage. With liquid flow, it may be necessary to purge air from the system before reading stabilize. No lubrication or periodic servicing is required. Keep case exterior, including front cover, clean for best visibility.

Variable Area Flowmeters used for gases are typically labeled with the prefix "S" or "N", which represents "Standard" for English units or "Normal" for metric units. Use of this prefix designates that the flowmeter is calibrated to operate at a specific set of conditions, and deviation from those standard conditions will require correction for the calibration to be valid. In practice, the reading taken from the flowmeter scale must be corrected back to standard conditions to be used with the scale units. The correct location to measure the actual pressure and temperature is at the exit of the flowmeter, except under vacuum applications where they should be measured at the flowmeter inlet. The equation to correct for nonstandard operating conditions is as follows:

$$Q_2 = Q_1 \times \sqrt{\frac{P_1 \times T_2}{P_2 \times T_1}}$$

Where:  $Q_1$  = Actual or Observed Flowmeter Reading

$Q_2$  = Standard Flow Corrected for Pressure and Temperature

$P_1$  = Actual Pressure (14.7 psia + Gage Pressure)

$P_2$  = Standard Pressure (14.7 psia, which is 0 psig)

$T_1$  = Actual Temperature (460 R + Temp °F)

$T_2$  = Standard Temperature (530 R, which is 70°F)

Example: A flowmeter with a scale of 10-100 SCFH Air. The float is sitting at the 60 grad on the flowmeter scale. Actual Pressure is measured at the exit of the meter as 5 psig. Actual Temperature is measured at the exit of the meter as 85°F.

$$Q_2 = 60.0 \times \sqrt{\frac{(14.7 + 5) \times 530}{14.7 \times (460 + 85)}}$$

$Q_2 = 68.5$  SCFH Air

## More Information

Contact factory for additional information including conversion curves, correction factors and other types and ranges of Dwyer flowmeter.