

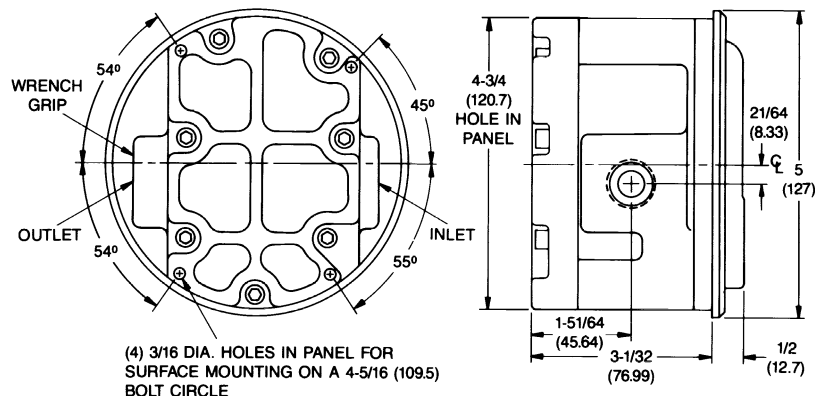

Series RMV Rate-Master® Flowmeters

Specifications — Installation and Operating Instructions

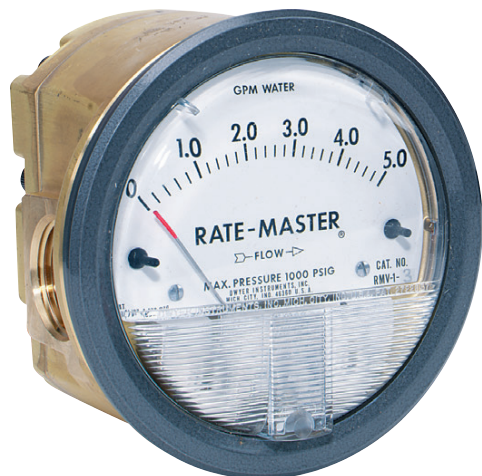

Series RMV Rate-Master® Dial-Type Flowmeters provide accurate, dependable measurement of water flows to 20 GPM. Installed in-line, they employ a “target” type element linked to a flexible leaf spring which deflects in proportion to the force generated by the flowing medium. A magnet attached to the free end of the spring drives a mating magnet to which the indicating pointer is attached. Because the spring/magnet assembly is isolated from the mating magnet/pointer assembly by a wall in the brass casting, there is no direct mechanical linkage. This means units can easily withstand over-range flows to 150% without damage and there is no path for leaks. This construction also allows units to be specially calibrated for dark and/or opaque liquids which would be impossible to see with typical rotameter style instruments. Models are available with 1/2”, 3/4” or 1” female connections.

CALIBRATION

All Series RMV flowmeters are calibrated at the factory for mounting with scale vertical and flow from left to right when facing unit. They must be used in that position for accurate readings. If flowmeter was specially calibrated for some other position, it will be marked accordingly.

These flowmeters will normally retain their original accuracy for the life of the device. If, at any time you want to check calibration, do so only with instruments of certified accuracy. Do not attempt to check Dwyer RMV Rate-Master® flowmeters with other flowmeters piped in a series. Even minor variations in piping and back pressure can cause a significant difference in indication. Your Dwyer flowmeter may be returned to the factory for a calibration check at no charge. This no-charge check does not include written certification or any repairs necessary to restore proper operation.

SPECIFICATIONS

Service: Compatible liquids.

Wetted Materials: Brass, copper, 302 SS, sintered barium ferrite.

Temperature Limits: 20 to 200°F (-6.7 to 93°C).

Pressure Limit: 1000 psig (68.9 bar).

Pressure Drop: 0-5 GPM: 3.2 PSID; 0-10 GPM: 5.3 PSID; 0-20 GPM: 10.4 PSID.

Accuracy: ±2% of full scale.

Size: Diameter dial face 4” (101.6 mm).

Process Connections: See Chart.

Maximum Flow: 1.5 x full scale reading.

Weight: 9 lb (4.08 kg).

Model Number	Range, GPM Water	Connection Size
RMV-1-3	0-5	1" female NPT
RMV-2-3	0-10	1" female NPT
RMV-3-3	0-20	1" female NPT
RMV-1-2	0-5	3/4" female NPT
RMV-2-2	0-10	3/4" female NPT
RMV-3-2	0-20	3/4" female NPT
RMV-1-1	0-5	1/2" female NPT
RMV-2-1	0-10	1/2" female NPT
RMV-3-1	0-20	1/2" female NPT

LOCATION

Select a location where the flowmeter can be easily read and where the temperature will not exceed 200°F (93°C). The mounting surface and piping to the flowmeter should be free from excessive vibration. If pulsing flow or vibration causes excessive pointer oscillation, contact factory for ways to provide additional dampening.

PIPING

Inlet Piping: It is good practice to approach the flowmeter inlet with as few elbows, restrictions, and size changes as possible. Inlet pipe should be as close to the flowmeter connection size as practical to avoid turbulence which can occur with drastic size changes. The length of inlet piping has little effect on normal pressure-fed flowmeters.

Discharge Piping: Piping on the discharge side should be at least as large as the flowmeter connection.

Zero Setting: The RMV Rate-Master® flowmeter is calibrated and zeroed in a specific (normally vertical) position at the factory. If the gage is used in any other position, it may be necessary to adjust the zero setting. Position changes can adversely affect accuracy.

If re-zeroing is required, hold the brass case firmly with one hand and turn the grey bezel cover counterclockwise to remove. Next, lift off the plastic cover. Hold the 5/32" diameter brass knob below the pointer axis stationary and adjust the rectangular brass blade between axis and knob. Repeat adjustments as necessary until flowmeter reads exactly zero when held in its intended mounting position.

To replace the cover, align the (2) 1/8" slots on the edge with matching 1/8" projections on the case adjacent to the pointer bumpers. Install the bezel ring, hold cover in place with palm of hand and turn ring clockwise until tight.

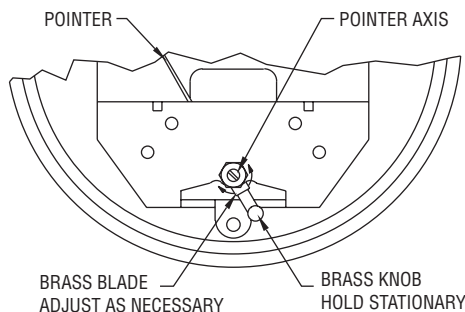

MOUNTING

In-Line Mounting: Flowmeter may be installed in-line supported only by the piping. A square wrench surface surrounds the outlet port to aid in assembly.

Surface Mounting: Drill (4) 3/16" diameter holes in the panel using dimensions shown in the drawing below. Attach with 6-32 machine screws of appropriate length. For many metal panels the 5/16" screws included can be used.

Flush Mounting: If required, re-zero flowmeter before panel mounting. Provide a 4-3/4" (120 mm) opening in panel. Place flowmeter into opening and attach (4) mounting lugs to rear of case with 6-32 X 5/16" machine screws. Secure unit in place by tightening (4) 6-32 X 3-1/2" screws through the mounting lugs against the rear of the panel.

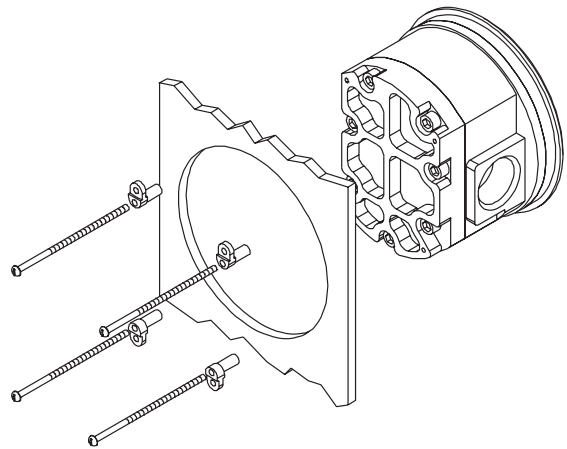

OPERATION

If flowing media is dirty, install a 50-micron filter upstream from the flowmeter inlet. After all connections are complete, introduce flow as slowly as possible to avoid damage. With liquid flows, it may be necessary to purge air from the system before pointer readings stabilize.

MAINTENANCE

The moving parts of these flowmeters need no routine maintenance or lubrication. The only adjustment is the zero setting which should be checked periodically. Units in need of repair should be returned to the factory prepaid. Field repair is not recommended.