

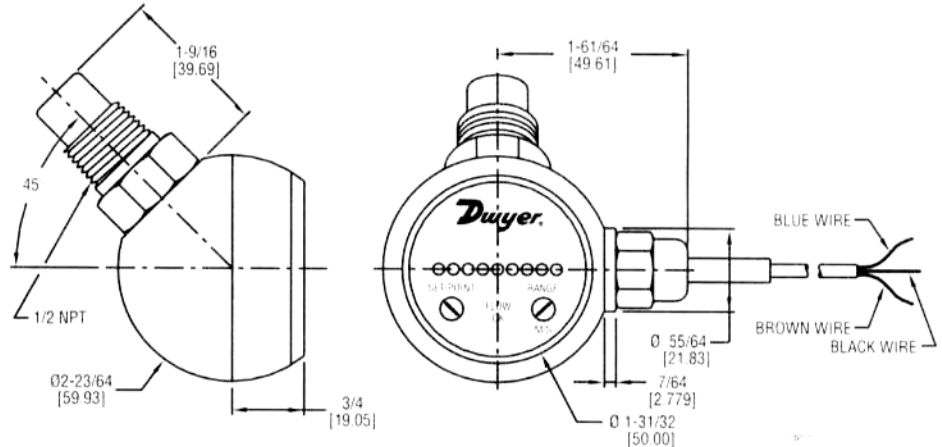

SERIES TFS THERMAL FLOW SENSOR

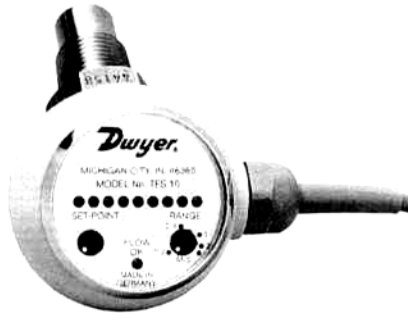

Specifications – Installation and Operating Instructions



GENERAL

The Series TFS Flow Switch with adjustable setpoint monitors flow rates utilizing a calorimetric design. Units feature a string of LEDs to indicate percentage of flow range and setpoint value.

MECHANICAL INSTALLATION

The Series TFS Thermal Flow Switch should be mounted in a location of minimum turbulence to obtain highest accuracy. A straight run of pipe consisting of five pipe diameters upstream and three pipe diameters downstream is recommended. The sensor can be mounted in a tee fitting or a fitting welded to the pipework. Install the sensor into the pipe at a sufficient depth to ensure the sensing face is in contact with the flowing medium at all times (laminar flow area within the pipe). The NPT thread should be sealed with Teflon[®] tape or other commercial sealer. The Series TFS Thermal Flow Switch can be mounted in a vertical or horizontal orientation. The preferred position is in a vertical pipe with an upward flow. In a horizontal pipe, the sensor should be mounted on the side. Final position should have the LED chain horizontal and reading left to right.

The sensor is supplied with a plastic cover to protect from pollution and unauthorized adjustment. To fit the cover onto the face, pull paper tab surrounding the face dial. Place plastic cover on face and push until secure. Remove protective sheet from plastic cover.

ELECTRICAL INSTALLATION

- 1) Gently insert the plug and cable assembly into the switch body.
- 2) Tighten the cable nut to secure assembly.
- 3) Connect the blue wire to the negative of the power supply.
- 4) Connect the brown wire to positive of the power supply.
- 5) The black wire should be connected to the load and then to negative side of loop. See Figure 1.

PHYSICAL DATA

Media: Water-based fluids

Measuring Range: 0.2 m/s (0.66 ft/s) to 3.0 m/s (9.8 ft/s).

Setpoint Range: 15% to 90% of range setting.

Response Time: 2 to 10 seconds (relative to range setting).

Repeatability: Less than 2.0%.

Linearity: Less than 5%.

Hysteresis: 10% (approximate).

Maximum Pressure: 435 psi (30.0 bar).

Operating Temperature Range: -4° to 176°F (-20° to 80°C).

Supply Voltage: 18 to 30 VDC, including residual ripple.

Switching Current: 400 mA maximum.

Current Consumption: 150 mA maximum.

Power Consumption: 1 watt (approximate).

Process Connection: 1/2" -14 NPT(M).

Electrical Connection: Plug-in 78" (198 cm) oilflex cable.

Circuit Protection: Reverse polarity, short-circuit, and overload.

Protection Standard: IP 65.

Sensor Material: 303 Stainless Steel.

Housing Material: PBTP, glass fiber reinforced (Ultradur)

Weight: 0.66 lbs (301g).

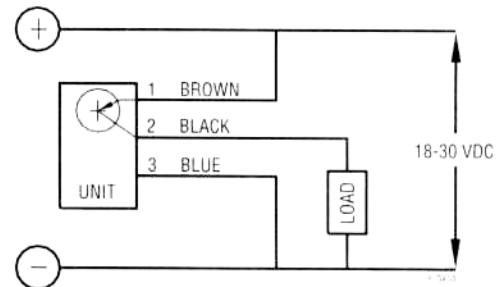

FIGURE 1

NOTE: When power is initially supplied to the unit, the entire LED string and green "Flow OK" LED will light for approximately 10 seconds. After the initial warm-up time, the green LED will go off, the first LED will be lit, and the setpoint LED will flash.

OPERATION

Flow range and setpoint values are adjusted by two independent potentiometers located on the face of the unit. The flow rate is continuously displayed on a LED string. The setpoint is displayed by a flashing LED within the LED string. See Figure 2 below.

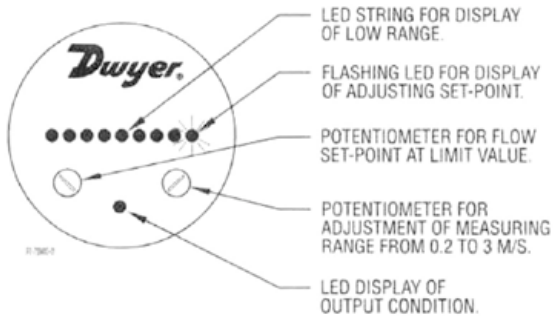

FIGURE 2

Measurement of Flow Speed

The Series TFS Thermal Flow sensors are calibrated for water. Other media will result in a change scaled ranges, particularly mediums with different thermal conductivity. To adjust the Series TFS Thermal Flow Switch to indicate actual flow speed:

- 1) Turn the range potentiometer to the maximum setting of 3 m/s (9.8 ft/s).
- 2) A portion of the LED chain will be lit representing the percentage of flow as compared to the 3 m/s (9.8 ft/s) setting.
- 3) Turn the potentiometer counterclockwise until all the LEDs are lit to determine the optimum flow range.
- 4) The flow speed is indicated by a white dot on the range potentiometer. Actual flow speed will be represented as a percentage of flow range, based on the number of LEDs lit, i.e. all LEDs lit indicates 100% of flow range or actual flow speed.

It is possible to define any measuring range between 0-20 cm/s (0.66 ft/s) to 0-3 m/s (9.8 ft/s). Flow speed indication is shown in steps of approximately 10% of the adjusted range. Each lit LED represents an additional 10% of indicated flow range.

Setpoint Adjustment

The setpoint can be any value within the adjustment range and can be adjusted by turning the setpoint potentiometer. The setpoint is indicated on the LED chain by a flashing LED, which represents a percentage of the maximum value of the flow speed range. The resolution of the setpoint adjustment depends on the range adjustment. Resolution on the LED chain is shown in steps of approximately 10%. For example, the resolution for the 0-2 m/s (6.6 ft/s) range is approximately 20 cm/s (0.65 ft/s) per lit LED in the chain. The green "Flow OK" will be lit if the flow speed is above the setpoint.

Sampling Rate

To avoid false signals due to small irregularities in flow, the output signal is based on an average flow speed over a given period. The sampling rate is related to the range, i.e. at low range 0.2 m/s (0.66 ft/s) the sampling rate is 8 seconds, and at maximum range 3.0 m/s (9.8 ft/s), the sampling rate is less than 2 seconds. This can be observed by the flashing rate of the setpoint LED.

Examples of Operation

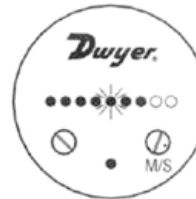

Measuring range adjusted to 3 m/s (9.8 ft/s)
 Flow rate 75% of 3 m/s (9.8 ft/s) = 2.26 m/s (7.38 ft/s)
 Limit value 50% of adjusted measuring range = 1.5 m/s (4.9 ft/s)
 LED is on, flow is greater than limit value

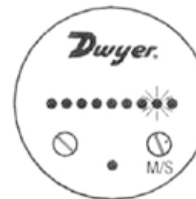

Measuring range = nominal value, adjusted to 1.5 m/s (4.9 ft/s)
 Flow rate \geq nominal value
 Limit value 10% below nominal value
 LED is on, flow is greater than limit value

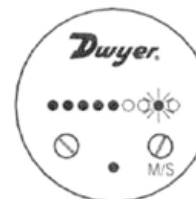

Measuring range adjusted to 3 m/s (9.8 ft/s)
 Nominal rate = actual rate = 1.5 m/s (4.9 ft/s)
 Limit value 40% above nominal value
 LED is off, flow is below limit value

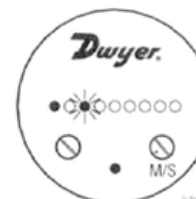

Measuring range adjusted to 20 cm/s (0.66 ft/s)
 Flow rate 15% of measuring range = 3 cm/s (0.1 ft/s)
 Limit value at 30% of measuring range = 6 cm/s (0.2 ft/s)
 LED is off, flow is below limit value

MAINTENANCE

Periodic check of output calibration and connections is recommended. Units are not field serviceable and should be returned to the factory, freight prepaid, if repair is necessary. Be sure to include a complete description of the application and problem.

