



Series UV In-Line and Panel Mount Polysulfone Flowmeter

Specifications - Installation and Operating Instructions



Picture at left shown with optional Polysulfone Fittings.

Optional Polycarbonate Shield

Drawing at right shown with optional Polysulfone Fittings.

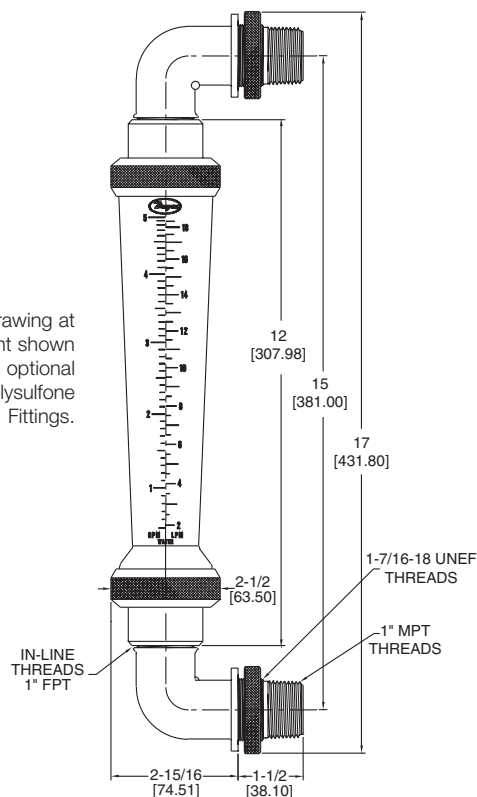

The Series UV In-Line Polysulfone Flowmeter measures the flow of water, air, and other compatible media at temperatures up to 212°F (100°C) and pressures up to 150 psi (10.34 bar). This flowmeter's highly corrosion-resistant materials suit it ideally for use with de-ionized water and ultra-pure applications, including food processing, medical equipment and reverse osmosis water systems.

INSTALLATION

1. Select an indoor (only) location that is free from excess vibration, within the specified temperature limits, and away from direct sunlight. (Polysulfone is adversely affected by ultra-violet light.)
2. Remove hollow plastic shipping tube from inside flow body.
3. Handle carefully. Hand-tighten aluminum ring. O-Rings will seal if hand tightened only. Do not overtighten the adapters and fittings.
4. Install the flowmeter in an exact vertical plane, one that is in proper alignment with the existing plumbing. Use wall or other structural supports at the top and bottom of the unit. Do not allow the instrument to support the weight of pipes or tubing.
5. Use Teflon® tape thread sealant. Do not use pipe dope compounds, which can craze and crack the polysulfone housing. Hand tighten system pipe fitting to adaptor fitting. If additional torque is needed to seal pipe joint, use strap wrench on adaptor fitting. Maximum torque is 22 Foot - Pounds.

6. If using solvent-based glues like PVC cement, in the piping system, do so with the meter's body removed until glue has cured, then purge the system before re-installing. Do not solder brass fittings with the body installed, because the heat generated to solder the brass fittings will damage the flowmeter.

CAUTION: Ball valves and solenoid valves can have a "water cannon" effect on opening, creating pressure that exceeds the warranted ratings and will damage the flowmeter.

SPECIFICATIONS

Service: Compatible liquids.

Wetted Materials: Polysulfone body, Viton® O-Rings and Virgin PTFE float.

Temperature Limits: 35 to 212°F (2 to 100°C); 35 to 130°F (2 to 54°C) for PVC Fitting Option.

Pressure Limit: 150 psi (10.34 bar).

Accuracy: ±2% Full Scale @ 70°F +/- 2 F (21.1°C) and 14.7 psia (In line connection rating only).

Repeatability: +/-1% full scale @ 70+/-2°F (21.1°C) and 14.7 psia (In line connection rating only).

Process Connections: 1" female NPT. Optional 90° Polysulfone Elbow – 1" male NPT.

Scale Length: 6" (152.40) – 7" (177.80), depending on model.

Fitting Torque: Maximum 22 ft - lb.

Weight: 1 lb (457 g) (for 20 GPM range).

Teflon, Viton-Reg.™ E.I. du Pont de Nemours & Co.

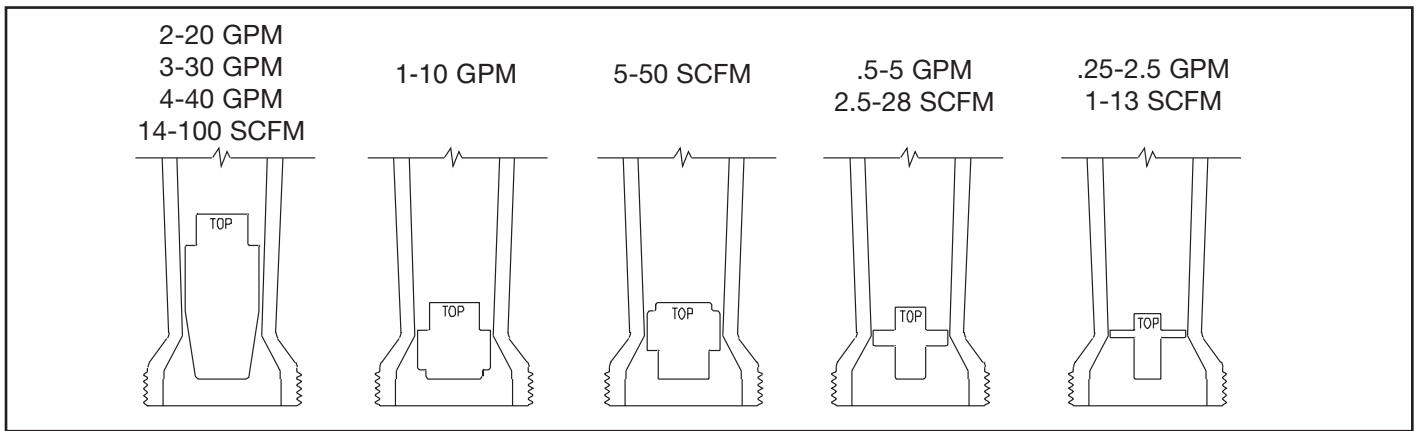

OPERATION AND MAINTENANCE

Once installed, the Series UV In-Line Polysulfone Flowmeter is self-operating and requires no maintenance other than an occasional cleaning with mild soap and a bottle brush. For this purpose, the unit has been designed so that its body can be removed quickly and easily while leaving all fittings intact.

When removing float for cleaning, note the floats "up" position. The float is a precision part and must be reassembled without adverse treatment, i.e. dropping, denting, and surface abrasion.

The standard technique for reading a Variable Area Flowmeter is to locate the highest point of greatest diameter on the float, and then align that with the theoretical center of the scale graduation. In the event that the float is not aligned with a grad, an extrapolation of the float location must be made by the operator as to its location between the two closest grads. The following are some sample floats shown with reference to the proper location to read the float.



Variable Area Flowmeters used for gases are typically labeled with the prefix "S" or "N", which represents "Standard" for English units or "Normal" for metric units. Use of this prefix designates that the flowmeter is calibrated to operate at a specific set of conditions, and deviation from those standard conditions will require correc-

tion for the calibration to be valid. In practice, the reading taken from the flowmeter scale must be corrected back to standard conditions to be used with the scale units. The correct location to measure the actual pressure and temperature is at the exit of the flowmeter, except under vacuum applications where they should be measured at the flowmeter inlet. The equation to correct for nonstandard operating conditions is as follows:

$$Q_2 = Q_1 \times \sqrt{\frac{P_1 \times T_2}{P_2 \times T_1}}$$

- Where:
- Q_1 = Actual or Observed Flowmeter Reading
 - Q_2 = Standard Flow Corrected for Pressure and Temperature
 - P_1 = Actual Pressure (14.7 psia + Gage Pressure)
 - P_2 = Standard Pressure (14.7 psia, which is 0 psig)
 - T_1 = Actual Temperature (460 R + Temp °F)
 - T_2 = Standard Temperature (530 R, which is 70°F)

Example: A flowmeter with a scale of 10-100 SCFH Air. The float is sitting at the 60 grad on the flowmeter scale. Actual Pressure is measured at the exit of the meter as 5 psig. Actual Temperature is measured at the exit of the meter as 85°F.

$$Q_2 = 60.0 \times \sqrt{\frac{(14.7 + 5) \times 530}{14.7 \times (460 + 85)}}$$

$$Q_2 = 68.5 \text{ SCFH Air}$$

Models and Ranges

Model Number	Range	Medium	Body	Fitting Material	Float
UV-0112	0.25-2.5 GPM (1-9.5 LPM)	Water	Polysulfone	Polysulfone	Virgin PTFE
UV-1112	0.5-5.0 GPM (2-19 LPM)	Water	Polysulfone	Polysulfone	Virgin PTFE
UV-2112	1.0-10.0 GPM (4-38 LPM)	Water	Polysulfone	Polysulfone	Virgin PTFE
UV-3112	2.0-20.00 GPM (8-76 LPM)	Water	Polysulfone	Polysulfone	Virgin PTFE
UV-4112	3.0-30.00 GPM (12-112 LPM)	Water	Polysulfone	Polysulfone	Virgin PTFE
UV-5112	4.0-40.00 GPM (20-150 LPM)	Water	Polysulfone	Polysulfone	Virgin PTFE
UV-A112	1-13 SCFM (30-370 LPM)	Air	Polysulfone	Polysulfone	Virgin PTFE
UV-B112	2.5-28 SCFM (70-780 LPM)	Air	Polysulfone	Polysulfone	Virgin PTFE
UV-C112	5-50 SCFM (70-1400 LPM)	Air	Polysulfone	Polysulfone	Virgin PTFE
UV-D112	14-100 SCFM (400-2800 LPM)	Air	Polysulfone	Polysulfone	Virgin PTFE