

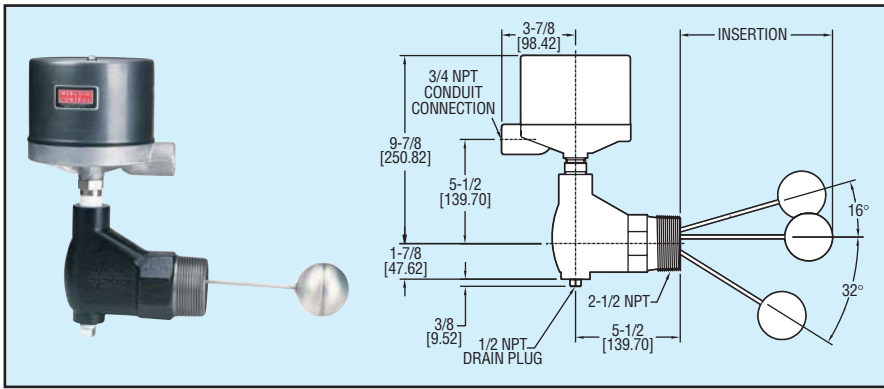

Series
500

Insertion Type Level Control

Adjustable Deadband, Weatherproof Enclosure



Adjustable deadband makes Model 500 ideal for control of level in large or small tanks. Mounts directly to threaded fitting on tank. (Flanged mounting available on special order.) Stainless steel float operates hermetically sealed mercury switch or SPDT snap action switch. Available in a variety of materials to match most petrochemical and industrial applications.

MODELS

Model Number	Switch Type	Body Material
500T-WT-7810-C.55-12-0	Snap Action	Cast Iron
500T-WT-7810-C1.55-12-0	Snap Action	Cast Steel
500T-WT-7810-C216.55-12-0	Snap Action	316 SS
500T-WT-4810-C.55-12-0	Mercury	Cast Iron
500T-WT-4810-C1.55-12-0	Mercury	Cast Steel
500T-WT-4810-C216.55-12-0	Mercury	316 SS

SPECIFICATIONS

Service: Compatible liquids. Cast iron is not for use with lethal or flammable substances either liquid or gaseous.

Wetted Materials:

Body: Cast iron, cast steel, or 316 SS.
Float and Trim: 316 SS.

Temperature Limit: 425°F (218°C).

Pressure Limit: 400 psig (27.6 bar).

Enclosure Rating: NEMA 4X. Optional general purpose or explosion-proof.

Switch Type: SPDT snap switch or mercury switch. Optional DPDT or hermetically sealed snap switch.

Electrical Rating: Snap Switch: 12A @ 120 VAC, 5A @ 240 VAC, 0.5A @ 125 VDC resistive, 0.25A @ 250 VDC resistive. Mercury Switch: 4A @ 120 VAC/DC, 2A @ 240 VAC/DC. Higher contact ratings available for the Mercury switch.

Electrical Connections: Screw terminal.

Conduit Connection: 3/4" female NPT.

Process Connections: 2-1/2" male NPT. Optional 2-1/2" flange.

Mounting Orientation: Vertical.

Set Point Adjustment: At minimum deadband setting the set point is adjustable approximately $\pm 1/2"$ (12.7 mm).

Weight: 35 lb (15.9 kg).

Agency Approvals: UL.

Deadband: Adjustable between 0.5" (12.7 mm) to 3" (76.2 mm).

Specific Gravity: 0.8 minimum. Optional 0.55 minimum.

Float and Rod Insertion Length: 6.5" (165.1 mm). Optional 12" (304.8 mm), 18" (457.2 mm), or 24" (609.6 mm) rod length. Longer float rods give larger adjustable deadband.

Level



Series
75

Torque Tube Type Level Control

Direct Action, Mercury Contacts

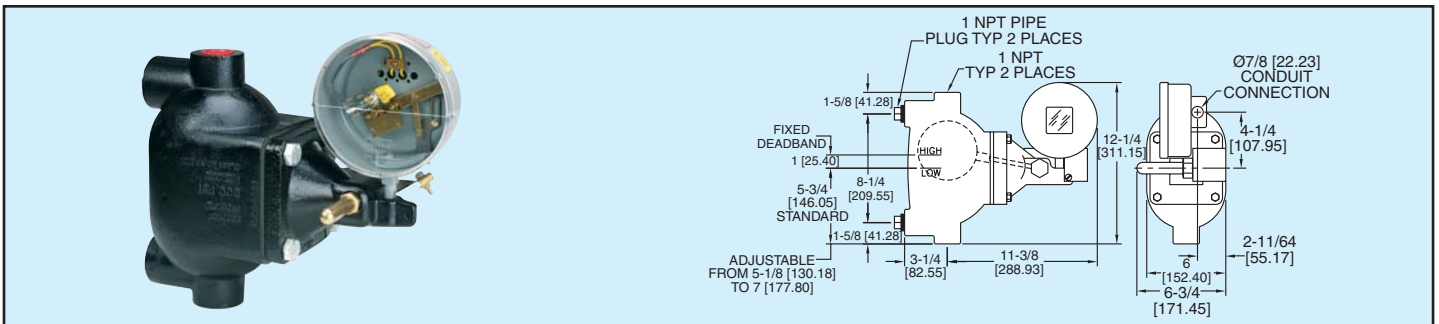

Torque Tube design eliminates O-rings and packing in Model 75 level controls. Float assembly removes easily from chamber for periodic inspection. "Flow Through" connections reduce piping requirements and installation time.

MODELS

Model Number	Chamber	Torque Tube
75KM-A-4815	Cast Iron	Brass
75KXM-A1-4815	Cast Steel	Brass
75KXM-A2-4815	304 SS	Brass
75KM-C-4815	Cast Iron	304 SS
75KXM-C1-4815	Cast Steel	304 SS
75KXM-C2-4815	304 SS	304 SS

SPECIFICATIONS

Service: Compatible liquids. Cast iron is not for use with lethal or flammable substances either liquid or gaseous.

Wetted Materials: Body: Cast iron, cast steel, or 304 SS. Float: 304 SS. Torque Tube: Brass or 304 SS. Body Gasket: Carbon.

Temperature Limit: Cast iron body: 425°F (218°C), cast steel or 304 SS body: 500°F (260°C).

Pressure Limit: Cast iron body: 300 psig (20.7 bar), cast steel or 304 SS body: 400 psig (27.6 bar).

Enclosure Rating: General purpose.

Switch Type: SPDT mercury switch. Optional SPST or two stage.

Electrical Rating: 10A @ 120 VAC/DC, 5A @ 240 VAC/DC.

Electrical Connections: Screw terminal.

Conduit Connection: 7/8" (22.23 mm) hole for 1/2" (12.7 mm) conduit.

Process Connections: 1" female NPT. Four for side/side or top/bottom mounting.

Mounting Orientation: Vertical.

Weight: 35 lb (15.9 kg).

Agency Approvals: UL and CSA.

Deadband: Approximately 1" (25.4 mm).

Specific Gravity: 0.66 minimum.