

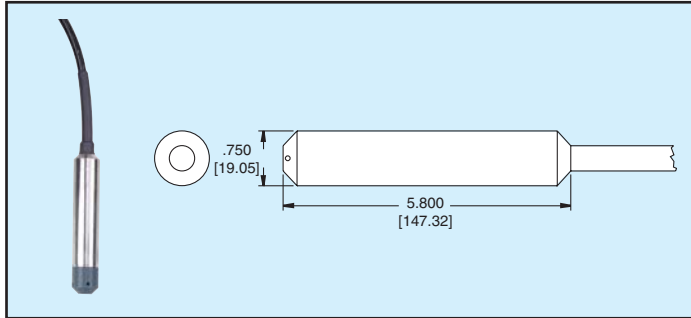

Series
SBLT

Submersible Level Transmitter

Perfect for Ground Water and Wells, Lightning Protected



SBLT Submersible Level Transmitter is manufactured for years of trouble free service. The transmitter consists of a bonded foil, strain gauge, sensing element, encased in 316 SS housing. Superior lightning and surge protection utilizing dual arrestor technology, grounded to case, eliminating both power supply surges and lightning ground strike transients. Bullet nose design protects diaphragm from damage. Comes equipped with a 220-pound tensile strength, shielded, vented, Polyurethane cable. Ventilation tube in the cable automatically compensates for changes in atmospheric pressure above the tank. The vent is protected with a filter eliminating moisture collection in the transducer.

APPLICATIONS

- Well monitoring; Ground water monitoring; Environmental remediation; Surface water monitoring; Down hole; Water Tanks

SPECIFICATIONS

Service: Compatible liquids.
Wetted Materials: Body: 316 SS, Cable: Polyurethane. Bullet Nose: PVC.
Accuracy: $\pm 0.20\%$ of full scale.
Temperature Limits: -40 to 150°F (-40 to 65.6°C).
Compensated Temperature Range: 0 to 140°F (-17.8 to 60°C).
Pressure Limit: 1.5X full scale range.
Thermal Effect: Less than $\pm 2.0\%$ of full scale per 100°F.
Power Requirement: 9 to 36 VDC.
Output Signal: 4 to 20 mA DC, 2-wire.
Response Time: < 5 ms.
Loop Resistance: 750 ohms at 24 VDC
Electrical Connections: Wire pigtail.
Mounting Orientation: Suspended in tank below level being measured. Can be placed on the bottom of the tank on its side.
Standard Features: Calibration certificate.
Weight: 3.5 lb (1.59 kg).
Electrical Protection: Dual transient lightning and surge arrestors exceeding FM approved I/S and meet EMA/RFI standards Mil-Std 461/462 and ground to transducer case.

MODELS

Model Number	Pressure Range	Cable Length
SBLT-5-40	5 psi (.35 bar)	40 feet (12.2 m)
SBLT-10-40	10 psi (.69 bar)	40 feet (12.2 m)
SBLT-15-60	15 psi (1.03 bar)	60 feet (18.3 m)
SBLT-20-60	20 psi (1.39 bar)	60 feet (18.3 m)

Extended cable length available contact the factory.

Level



Series
SPT

Submersible Pressure Transmitter

Stainless Steel Housing, Fully Submersible, 4-20 mA or 0-5 VDC Output

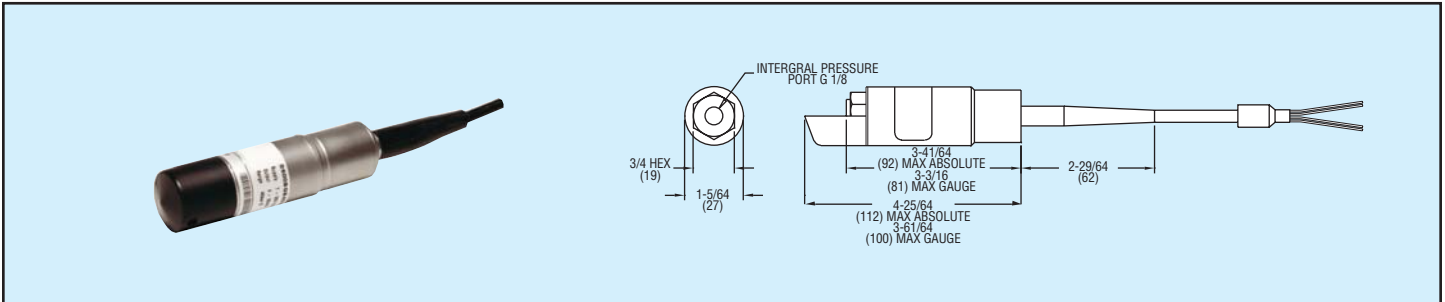

The **Series SPT Submersible Pressure Transducer** features stability and accuracy for the most demanding submersible and industrial applications. Units include a plastic nose cone to protect the sensing element. The rugged stainless steel construction and the 81 foot (24.6 m) cable add an element of durability and versatility to this transducer. Units include circuitry for protection against noise, voltage spikes, and static discharge. The submersible transmitter is an excellent choice for ground water monitoring, reservoirs, waste water, well monitoring, flood channels and landfills.

MODELS

Model	Range	Output
SPT-101381	0-15 psi	0-5V
SPT-401381	0-15 psi	4-20 mA

SPECIFICATIONS

Service: Compatible liquids.
Wetted Materials: 17-4 PH SS and ABS Plastic.
Accuracy: $\pm 0.25\%$ FS.
Stability: $\pm 0.2\%$ of F.S. for 1-year (non-cumulative).
Temperature Limits: -5 to 180°F (-20 to 82°C).
Pressure Limits: $\pm 2\%$ of FS.
Thermal Effect: 1.5% FS.
Power Requirements: 24 VAC.
Output: 4-20 mA DC or 0-5 VDC 2-wire.
Loop Resistance: 850 ohms @24 VDC.
Electrical Connection: Moulded immersible cable.
Process Interface: Plastic nose cone.
Enclosure: 316 SS, 17-4 PH SS.
Weight: 1lb (100 g).