



**B Series Temperature Controller
Instruction Sheet**

Thank you very much for purchasing a Love Controls Series B Temperature/Process Controller. Please read this instruction sheet before using your controller to ensure proper operation and please keep this instruction sheet handy for quick reference.

1 Precaution

⚠ DANGER! Caution! Electric Shock!

1. Do not touch the AC terminals while the power is supplied to the controller to prevent an electric shock.
2. Make sure power is disconnected while checking the unit inside.
3. The symbol  indicates that this Controller is protected throughout by DOUBLE INSULATION or REINFORCED INSULATION (equivalent to Class II of IEC 536).





⚠ WARNING!

Mount the controller in a location that will not be subject to excessive temperature, shock, or vibration. All models are designed for mounting in an enclosed panel.

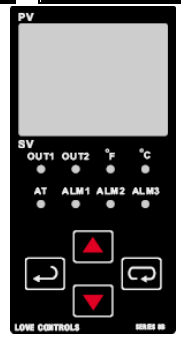
1. Always use recommended solder-less terminals: Fork terminal with isolation (M3 screw, width is 7.0mm (6.0mm for 32B Series), hole diameter 3.2mm). Screw size: M3 x 6.5 (With 6.8 x 6.8 square washer). Screw size for 32B Series: M3 x 4.5 (With 6.0 x 6.0 square washer). Recommended tightening torque: 0.4 N.m (4kgf.cm). Applicable wire: Solid/twisted wire of 2 mm², 12AWG to 24AWG. Please be sure to tighten them properly.
2. Do not allow dust or foreign objects to fall inside the controller to prevent it from malfunctioning.
3. Never modify or disassemble the controller.
4. Do not connect anything to the "No used" terminals.
5. Make sure all wires are connected to the correct polarity of terminals.
6. Do not install and/or use the controller in places subject to: Dust or corrosive gases and liquid, high humidity and high radiation, vibration and shock, high voltage and high frequency
7. Power must be off when wiring and changing a temperature sensor.
8. Be sure to use compensating wires that match the thermocouple types when extending or connecting the thermocouple wires.
9. Please use wires with resistance when extending or connecting a platinum resistance sensor (RTD).
10. Please keep the wire as short as possible when wiring a platinum resistance sensor (RTD) to the controller and please route power wires as far as possible from load wires to prevent interference and induced noise.
11. This controller is an open-type unit and must be placed in an enclosure away from high temperature, humidity, dripping water, corrosive materials, airborne dust and electric shock or vibration.
12. Please make sure power cables and signals from instruments are all installed properly before energizing the controller, otherwise serious damage may occur.
13. Please do not touch the terminals in the controller or try to repair the controller when power is applied to prevent an electric shock.
14. Wait at least one minute after power is disconnected to allow capacitors to discharge, and please do not touch any internal circuit within this period.
15. Do not use acid or alkaline liquids for cleaning. Please use a soft, dry cloth to clean the controller.
16. This instrument is not furnished with a power switch or fuse. Therefore, if a fuse or power switch is required, install the protection close to the instrument. Recommended fuse rating: Rated voltage 250 V, Rated current 1 A. Fuse type: Time-lag fuse
17. Note: This controller does not provide overcurrent protection. Use of this product requires that suitable overcurrent protection device(s) must be added to ensure compliance with all relevant electrical standards and codes. (Rated 250 V, 15 Amps max). A suitable disconnecting device should be provided near the controller in the end-use installation.

2 Display, LED and Pushbuttons



PV	displays process value
SV	displays setpoint value.
	INDEX: advances the display to the next menu item.
	UP ARROW: Increments a value or changes a menu item.
	DOWN ARROW: Increments a value or changes a menu item.
	ENTER: stores the value or item change.

Note 1: 32B Series does not support an additional alarm output, however, the user can set 2nd output as alarm mode.

Temperature Sensor Type and Temperature Range

Input Temperature Sensor Type	Register Value	LED Display	Temperature Range
0~50mV Analog Input	17	00	-999 ~ 9999
4~20mA Analog Input	16	004	-999 ~ 9999
0~20mA Analog Input	15	000	-999 ~ 9999
0V~10V Analog Input	14	010	-999 ~ 9999
0V~5V Analog Input	13	05	-999 ~ 9999
Platinum Resistance (Pt100)	12	Pt	-200 ~ 600°C
Platinum Resistance (JPt100)	11	JPt	-20 ~ 400°C
Thermocouple TXK type	10	TXK	-200 ~ 800°C
Thermocouple U type	9	U	-200 ~ 500°C
Thermocouple L type	8	L	-200 ~ 850°C
Thermocouple B type	7	B	100 ~ 1800°C
Thermocouple S type	6	S	0 ~ 1700°C
Thermocouple R type	5	R	0 ~ 1700°C
Thermocouple N type	4	N	-200 ~ 1300°C
Thermocouple E type	3	E	0 ~ 600°C
Thermocouple T type	2	T	-200 ~ 400°C
Thermocouple J type	1	J	-100 ~ 1200°C
Thermocouple K type	0	K	-200 ~ 1300°C

Note 1: An external 250Ω precision resistor should be connected when the current input is selected as the input temperature sensor type.

Note 2: **5P** (in the operation mode) specifies the decimal point position. All input types except thermocouple B, S, and R type, allow the decimal point position to be specified.

The default range of analog input is -999 ~ 9999. For example, when a 0~20mA analog input is selected as the input temperature sensor type, -999 indicates 0mA and 9999 indicates 20mA. If change the input range to 0 ~ 2000, then 0 indicates 0mA and 2000 indicates 20mA. One display scale is equal to 0.01mA.

Operation

There are three modes of operation: operation, regulation and initial setting. When power is applied, the controller will default to the operation mode. Press the **↵** key to switch to regulation mode. If the **↵** key is pressed for more than 3 seconds, the controller will switch to the initial setting mode. Pressing the **↵** key while in the regulation mode or initial setting mode, forces the controller to return to the operation mode. PV/SV: Sets the temperature set point and displays the temperature process value. Use **↕** **↗** keys to set the temperature set point.

Setting method: While in any function mode, press the **↵** key to select the desired function and use the **↕** **↗** keys to change settings. Press **↵** key to save the changes. Menu items are listed below.

Regulation Mode	Operation Mode	Initial Setting Mode
AL Auto-tuning (Set in PID control and RUN mode) Press ↵ ↓	1234 Use ↕ ↗ key to set temperature set point Press ↵ ↓	Input Set input type Press ↵ ↓
PIdn 4 groups PID modes (n=0~3). When n=4, PID control is auto regulated. Press ↵ ↓ See PID Control Section	r-S Control setting RUN or STOP Press ↵ ↓ See "Execution" under Section 6	TPUn Set temperature unit do not display when analog input Press ↵ ↓
Pdof PD control offset setting (When PID control is ON and Ti=0, set the value of Pdof. Press ↵ ↓	PtRN Start pattern setting. Appears only when r-S is set to PStP Press ↵ ↓	TP-H Set upper-limit of temperature range Press ↵ ↓
HtS Heating hysteresis setting (Set in ON/OFF control mode) Press ↵ ↓	5P Decimal point position selection (except for B, S, R type, all the other types can be set) Press ↵ ↓	TP-L Set lower-limit of temperature range Press ↵ ↓
CtS Cooling hysteresis setting (Set in ON/OFF control mode) Press ↵ ↓	AL 1H Upper-limit alarm 1 (This parameter is available only when ALA1 function enables) Press ↵ ↓	Ctrl Sets Control Mode: on/off, pid, Prog, or manual. (Set to ProG for ramp/soak patterns) See Pattern and set editing. Press ↵ ↓

HCPd or CLPd Heating/Cooling control cycle setting (Set in PID control mode) Press	AL1L Lower-limit alarm 1 (This parameter is available only when ALA1 function enables) Press	PRbG Ramp/soak pattern. Only displayed when Ctrl is set to ProG. Press
HCPd Control cycle setting of 2nd output group (Set in PID control and Dual Loop output control mode) Press	AL2H Upper-limit alarm 2 (This parameter is available only when ALA2 function enables) Press	S-HC Select heating/cooling control or dual loop output control Press
CoEF P value of 1st & 2nd output group during dual loop output control P value of 2nd output group = (P value of 1st output group) x CoEF Press	AL2L Lower-limit alarm 2 (This parameter is available only when ALA2 function enables) Press	ALA1 Alarm 1 mode setting Press
DEAD Dead Band (Set in Dual Loop output control mode) Press	AL3H Upper-limit alarm 3 (This parameter is available only when ALA3 function enables) Press	ALA2 Alarm 2 mode setting Press
EPoF Regulate temperature deviation value Press	AL3L Lower-limit alarm 3 (This parameter is available only when ALA3 function enables) Press	ALA3 Alarm 3 mode setting Press
CrHL Regulate upper-limit of analog output value (The setting display when analog output) Press	LoL Setting lock mode Press	SALA Set system alarm Press
CrLo Regulate lower-limit of analog output value (The setting display when analog output) Press to return to auto-tuning mode	OUT1 Display and adjust output value of 1st output group (Display in PID control mode and manual RUN mode) Press	CoSH Communication write function enable/disable Press
	OUT2 Display and adjust output value of 2nd output group (Display in dual loop PID control mode and manual RUN mode) Press	C-SL ASCII, RTU communication format selection Press
		C-no Communication address setting Press
		bPS Communication baud rate setting Press
		LEN Data length setting Press
		Prty Parity bit setting Press
		StoP Stop bit setting Press to return input type setting

* 1 Scale = 2.8uA = 1.3mV for tuning output value

5	PID Control
----------	--------------------

PCd0 ~ **PCd4**: PIDn, n=0~4, found in the regulation mode, four groups of user-defined PID settings and an auto tuning function are available. Each group contains a set value, proportional band, integral time, derivative time, and integral deviation settings (P, I, D, IOF) for PID control. **PCd4**: n=4, is the auto PID parameter. The controller will automatically select a most useful PID parameter based on current temperature setting. Displayed SV values correspond to **Sv0** ~ **Sv3**

Sv0 ~ **Sv3**: is the temperature setting which corresponds to the selected PID parameter via user-defined or AT (auto-tuning). After AT(auto-tuning) the values will be stored.

PID mode selection (regulation mode): any one of four PID modes (n=0~3) can be selected. When n=4, the unit will perform auto-tuning.

P_{Ln} Select n=0~4 to decide PID mode. Press ↔ → 0~3 groups PID	S₀₀ PID setting: n=0. Press ↔ ↓	S₀₃ PID setting: n=3. Press ↔ ↓
	P₀ Proportion band setting: n=0. Press ↔ ↓	P₃ Proportion band setting: n=3. Press ↔ ↓
	T₀ Ti setting: n=0. Press ↔ ↓	T₃ Ti setting: n=3. Press ↔ ↓
	d₀ Td setting: n=0. Press ↔ ↓	d₃ Td setting: n=3. Press ↔ ↓
	CoF₀ Integral deviation setting: n=0. AT setting. Press ↔ ↓ back to PID deviation setting	CoF₃ Integral deviation setting: n=3. AT setting. Press ↔ ↓ back to PID deviation setting

6

Pattern and Set Editing (Ramp and Soak Programming)

Description of Function and Parameters Setting:

To set-up or edit the ramp/soak function, **Ctrl** in the initial setting mode must be set to **ProG**. **PrEn** will immediately follow in the menu list. The Ramp and Soak function is supported by 8 different patterns (Pattern No. 0~7). Each pattern contains 8 steps (step No. 0 ~ 7) for set point and execution time, one Link Pattern parameter, one Cycle parameter and one Actual Step parameter.

The set point (SV) should reach temperature X after the execution time T. The default of step No. 0 is soak control. The unit will control the temperature (PV) to reach the set point X and then keep the temperature at set point X. The execution time T is determined by step No, 0.

The following display is an example of operation of pattern No. 0. **PrEn** PAtn where n=0-7.

PrEn Select desired editing pattern number select OFF Press ↔ ↓ → select number	SP00 Edit temperature of step No. 0 of pattern No. 0 Press ↔ ↓	PS00 Select actual step No. when program control is executing Press ↔ ↓
Exit pattern and step editing selection Switch to S-HC and continue setting	EL00 Edit time of step No. 0 of pattern No. 0, unit is hh.mm Press ↔ ↓	CYC0 Set additional execution cycle number(0 to 99) Press ↔ ↓
	Set step No.1-7 in order	LCn0 Set link pattern, OFF indicates the program end Press ↔ to return pattern No. editing mode
	SP07 Edit temperature of step No. 7 of pattern No. 0 Press ↔ ↓	
	EL07 Edit time of step No. 7 of pattern No. 0, unit is hh.mm Press ↔ to set actual step No.	

Actual Step Parameter **PS_n**: Offered for each pattern (0-7), the user can select to execute only certain steps in the pattern. For example, when **PS₇** is set to 2, pattern No 7 will only execute steps 0 through 2.

Cycle Parameter **CYC_n**: Offered for each pattern (0-7), the cycle parameter will execute the selected pattern X amount of times. For example, when **CYC₄** is set to 2, pattern No. 4 will cycle through the steps and then cycle through the steps 2 more times.

Link Pattern Parameter **LC_n**: Offered for each pattern (0-7), the link parameter designates the next pattern to execute. For example, when **LC₀** is set to 2, pattern No. 2 will execute next after the execution of pattern No. 0. If **LC_n** is set to **OFF**, the program will stop after executing the current pattern and the temperature will be maintained at the set point of the last step.

Execution:

The execution of the ramp and soak function is initiated through **r-S** in the operation mode.

When **r-S** is set to **rUn**, the program will start to execute in order from the step 0 of the start pattern.

When **r-S** is set to **StoP**, the program will stop and the control output is disabled.

When **r-S** is set to **PS_{tP}**, the program will stop and the temperature will be maintained at the set point before program was stopped. Select **rUn** again, then the program will restart and execute from step 0 of start pattern. The start pattern setting **PrEn** is accessed when **r-S** is set to **PS_{tP}** and the INDEX key **↔** is pressed. (The start pattern setting only appears in **PS_{tP}** mode).

When **r-S** is set to **PHod**, the program will hold and the temperature at that time will be controlled at the set point before program hold. Select **rUn** again, then the program will follow the step before hold and start to execute through the rest of the time.

Display: During ramp and soak program control, the SV default display is P-XX, P indicates the current execution pattern and XX indicates the current execution step. Press **↕** **▲** to change the SV display item to set point value **SP** or residual time **r-tL**.

After selecting **SP**, press **↻** key, and then the temperature set point of the current execution step will display on SV display.

After selecting **r-tL**, press **↻** key, and then the residual time of the current execution step will display on SV display.

Heating, Cooling or Dual Loop Output Control

Temperature control can be achieved either by heating or cooling. In the B series, heating and cooling can be operated simultaneously (Dual Loop output control) to perform temperature control. When Dual Loop output control is used, two control outputs must be connected to the heating and cooling devices. Please refer to the following for the operation: Settings for heat, cool, or heat and cool are found in the initial settings mode under **5-WC**

Select **HEAT**, for heating (reverse) control on Output 1.

Select **COOL**, for cooling (forward) control on Output 1. By selecting **HEAT** or **COOL** the 2nd output group is regarded as an alarm output. For dual loop control, select **HE2** or **CO2**. When selecting **HE2**, the 1st output group is heating (reverse) control and the 2nd output group is cooling (forward) control. When selecting **CO2**, the 1st output group is cooling (forward) control and the 2nd output group is heating (reverse) control.

When dual loop control is selected

COEF Only visible when dual loop output and PID control method is configured. The parameter sets the P value of the 2nd output based on the P value of the 1st output which is set in parameter **Pdca**. The P value of 2nd output group is

equal to (P value of 1st output group) x **COEF** and the value of I and D of 2nd output group are the same as the value of I and D of 1st output group.

DEAD Dead Band, shown in figures 1, 2 and 3. This parameter sets an area in which the heating and cooling control output is 0 centering around the set point in a Dual Loop output control mode.

LoL : **Settings lock**. To avoid incorrect operation, two key lock functions are provided. **LoL1** : Lock 1 can lock all settings. All parameters and temperature settings can be locked to disable changes. **LoL2** : Lock 2 can lock settings except the SV (Set point) value. All parameters and temperature settings can be locked with the exception of the SV value. Press **LoL** and **LoL** key simultaneously, the "Lock" status can be released.

AT Auto-tuning parameter, automatically sets P (Proportional Band), I(Integral Time) and D(Derivative Time) parameters. Correct input must be connected to the unit for this parameter to be changed.

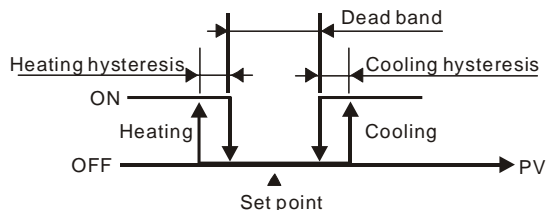

Figure 1. Output operation of ON/OFF control during dual loop output control

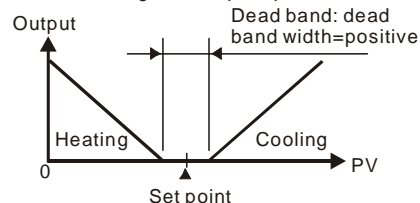

Figure 2. PID control, Dead Band is positive

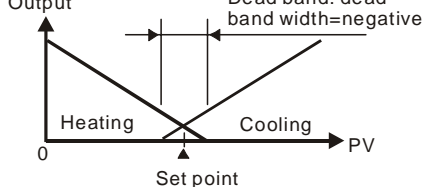

Figure 3. PID control, Dead Band is negative

Alarm Outputs

Depending on the controller model, there can be up to three alarm outputs. Each alarm output can be configured for an alarm type listed below. Alarm types are set in the initial setting mode. The alarm output is activated whenever the process temperature value (PV) is getting higher or lower than the set point of alarm limit.

Set Value	Alarm Type	Alarm Output Operation
0	Alarm function disabled	Output is OFF
1	Deviation upper- and lower-limit: This alarm output operates when PV value is higher than the setting value SV+(AL-H) or lower than the setting value SV-(AL-L).	ON OFF
2	Deviation upper-limit: This alarm output operates when PV value is higher than the setting value SV+(AL-H).	ON OFF
3	Deviation lower-limit: This alarm output operates when PV value is lower than the setting value SV-(AL-L).	ON OFF
4	Reverse deviation upper- and lower-limit: This alarm output operates when PV value is in the range of the setting value SV+(AL-H) and the setting value SV-(AL-L).	ON OFF
5	Absolute value upper- and lower-limit: This alarm output operates when PV value is higher than the setting value AL-H or lower than the setting value AL-L.	ON OFF
6	Absolute value upper-limit: This alarm output operates when PV value is higher than the setting value AL-H.	ON OFF
7	Absolute value lower-limit: This alarm output operates when PV value is lower than the setting value AL-L.	ON OFF

8	Deviation upper- and lower-limit with standby sequence: This alarm output operates when PV value reaches set point (SV value) and the value is higher than the setting value SV+(AL-H) or lower than the setting value SV-(AL-L).	
9	Deviation upper-limit with standby sequence: This alarm output operates when PV value reaches set point (SV value) and the reached value is higher than the setting value SV+(AL-H).	
10	Deviation lower-limit with standby sequence: This alarm output operates when PV value reaches the set point (SV value) and the reached value is lower than the setting value SV-(AL-L).	
11	Hysteresis upper-limit alarm output: This alarm output operates if PV value is higher than the setting value SV+(AL-H). This alarm output is OFF when PV value is lower than the setting value SV+(AL-L).	
12	Hysteresis lower-limit alarm output: This alarm output operates if PV value is lower than the setting value SV-(AL-H). This alarm output is OFF when PV value is higher than the setting value SV-(AL-L).	
13	CT alarm output: This alarm operates when the current measured by transformer (CT) is lower than AL-L or higher than AL-H (This alarm output is available only for the controller with current transformer).	
14	When program control is end status, alarm output is ON.	
15	When RAMP UP status happens to PID program control, alarm output is ON.	
16	When RAMP DOWN status happens to PID program control, alarm output is ON.	
17	When SOAK status happens to PID program control, alarm output is ON.	
18	When RUN status happens to PID program control, alarm output is ON.	

(Note: AL-H and AL-L include AL1H, AL2H, AL3H and AL1L, AL2L, AL3L)

9

Specifications

Input Voltage	100 to 240VAC 50/60Hz
Operation Voltage Range	85% to 110% of rated voltage
Power Consumption	5VA max.
Memory Protection	EEPROM 4K bit (non-volatile memory (number of writes: 100,000))
Display Method	2 line x 4 character 7-segment LED display Process value(PV): Red color, Set point(SV): Green color
Sensor Type	Thermocouple: K, J, T, E, N, R, S, B, L, U, TXK 3-wire Platinum RTD: Pt100, JPt100
Control Mode	PID, ON/OFF, Manual or PID program control (Ramp/Soak control)
Control Output	Relay output: SPDT (SPST: 1/16 DIN and 1/32 DIN size), Max. load 250VAC, 5A resistive load Voltage pulse output: DC 14V, Max. output current 40mA Current output: DC 4 ~ 20m A output (Load resistance: Max. 600Ω) Linear voltage output: 0~5V, 0~10V *(B Series only)
Display Accuracy	0 or 1 digit to the right of the decimal point (selectable)
Sampling Rate	Analog input: 150 msec/ per scan Thermocouple or Platinum RTD: 400 msec/per scan
RS-485 Communication	MODBUS ASCII / RTU communication protocol
Vibration Resistance	10 to 55Hz, 10m/s ² for 10min, each in X, Y and Z directions
Shock Resistance	Max. 300m/ s ² , 3 times in each 3 axes, 6 directions
Ambient Temperature	32 °F to 122 °F (0 °C to +50 °C)
Storage Temperature	-4 °F to 150 °F (-20 °C to +65 °C)
Altitude	2000m or less
Relative Humidity	35% to 80% (non-condensing)

10

RS-485 Communication

- Supporting transmission speed: 2400, 4800, 9600, 19200, 38400bps
- Non-supported formats: 7, N, 1 or 8, O, 2 or 8, E, 2
- Communication protocol: Modbus (ASCII or RTU)
- Function code: 03H to read the contents of register (Max. 8 words). 06H to write 1 (one) word into register. 02H to read the bits data (Max. 16 bits). 05H to write 1 (one) bit into register.
- Address and Content of Data Register:

Address	Content	Explanation
1000H	Process value (PV)	Measuring unit is 0.1, updated one time in 0.4 second The following reading value display indicates error occurs: 8002H : Initial process (Temperature value is not got yet) 8003H : Temperature sensor is not connected 8004H : Temperature sensor input error 8006H : Cannot get temperature value, ADC input error 8007H : Memory read/write error
1001H	Set point (SV)	Unit is 0.1, °C or °F
1002H	Upper-limit of temperature range	The data content should not be higher than the temperature range
1003H	Lower-limit of temperature range	The data content should not be lower than the temperature range
1004H	Input temperature sensor type	Please refer to the contents of the "Temperature Sensor Type and Temperature Range" for detail
1005H	Control method	0: PID, 1: ON/OFF, 2: manual tuning, 3: PID program control
1006H	Heating/Cooling control selection	0: Heating, 1: Cooling, 2: Heating/Cooling, 3: Cooling/Heating
1007H	1st group of Heating/Cooling control cycle	0~99, 0:0.5 sec
1008H	2nd group of Heating/Cooling control cycle	0~99, 0:0.5 sec
1009H	PB Proportional band	0.1 ~ 999.9
100AH	Ti Integral time	0~9999
100BH	Td Derivative time	0~9999
100CH	Integration default	0~100%, unit is 0.1%
100DH	Proportional control offset error value, when Ti = 0	0~100%, unit is 0.1%
100EH	Setting of COEF when Dual Loop output control are used	0.01 ~ 99.99
100FH	Setting of Dead band when Dual Loop output control are used	-999 ~ 9999
1010H	Hysteresis setting value of the 1st output group	0 ~ 9999
1011H	Hysteresis setting value of the 2nd output group	0 ~ 9999
1012H	Output value read and write of Output 1	Unit is 0.1%, write operation is valid under manual tuning mode only.
1013H	Output value read and write of Output 2	Unit is 0.1%, write operation is valid under manual tuning mode only.
1014H	Upper-limit regulation of analog linear output	1 Unit = 2.8uA(Current Output) = 1.3mV(Linear Voltage Output)
1015H	Lower-limit regulation of analog linear output	1 Unit = 2.8uA(Current Output) = 1.3mV(Linear Voltage Output)
1016H	Temperature regulation value	-999~+999, unit: 0.1
1017H	Analog decimal setting	0 ~ 3
101CH	PID parameter selection	0~4
101DH	SV value corresponded to PID value	Only valid within available range, unit: 0.1 scale
1020H	Alarm 1 type	Please refer to the contents of the "Alarm Outputs" for detail
1021H	Alarm 2 type	Please refer to the contents of the "Alarm Outputs" for detail
1022H	Alarm 3 type	Please refer to the contents of the "Alarm Outputs" for detail
1023H	System alarm setting	0 : None (default), 1~3 : Set Alarm 1 to Alarm 3
1024H	Upper-limit alarm 1	Please refer to the contents of the "Alarm Outputs" for detail
1025H	Lower-limit alarm 1	Please refer to the contents of the "Alarm Outputs" for detail
1026H	Upper-limit alarm 2	Please refer to the contents of the "Alarm Outputs" for detail
1027H	Lower-limit alarm 2	Please refer to the contents of the "Alarm Outputs" for detail
1028H	Upper-limit alarm 3	Please refer to the contents of the "Alarm Outputs" for detail
1029H	Lower-limit alarm 3	Please refer to the contents of the "Alarm Outputs" for detail
102AH	Read LED status	b0 : Alm3, b1: Alm2, b2: F, b3: , b4: Alm1, b5: OUT2, b6: OUT1, b7: AT
102BH	Read pushbutton status	b0 : Set, b1 : Select, b2 : Up, b3 : Down. 0 is to push
102CH	Setting lock status	0 : Normal, 1 : All setting lock, 11 : Lock others than SV value
102FH	Software version	V1.00 indicates 0x100
1030H	Start pattern number	0 ~ 7
1040H~1047H	Actual step number setting inside the correspond pattern	0 ~ 7 = N, indicate that this pattern is executed from step 0 to step N
1050H~1057H	Cycle number for repeating the execution of the correspond pattern	0 ~ 99 indicate that this pattern has been executed for 1 ~ 100 times
1060H~1067H	Link pattern number setting of the correspond pattern	0 ~ 8, 8 indicates the program end. 0~7 indicates the next execution pattern number after executing the current pattern
2000H~203FH	Pattern 0~7 temperature set point setting Pattern 0 temperature is set to 2000H~2007H	-999 ~ 9999
2080H~20BFH	Pattern 0~7 execution time setting Pattern 0 time is set to 2080H~2087H	Time 0 ~ 900 (1 minute per scale)

6. Address and Content of Bit Register: (First bit of reading will put into LSB, Write data = FF00H for bit set, 0000H for bit clear)

0810H	Communication write-in selection	Communication write in disabled: 0 (default), Communication write in enabled: 1
0811H	Temperature unit display selection	°C / linear input (default) : 1 , °F : 0
0812H	Decimal point position selection	Except for the thermocouple B, S, R type, all the other thermocouple type are valid. (0 or 1)
0813H	AT setting	OFF: 0 (default), ON : 1
0814H	Control RUN/STOP setting	0 : STOP, 1 : RUN (default)
0815H	STOP setting for PID program control	0: RUN (default), 1: STOP
0816H	Temporarily STOP for PID program control	0: RUN (default), 1: Temporarily STOP

7. Communication Transmission Format : Command Code: 02: read N bits, 05: write 1 bits, 03: read N words, 06: write 1 words

11 Panel Cutout and Terminals Identification

■ Panel Cutout (dimensions are in millimeter and inch)

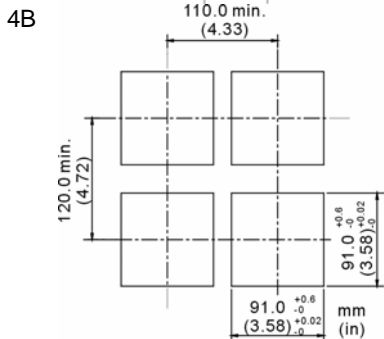
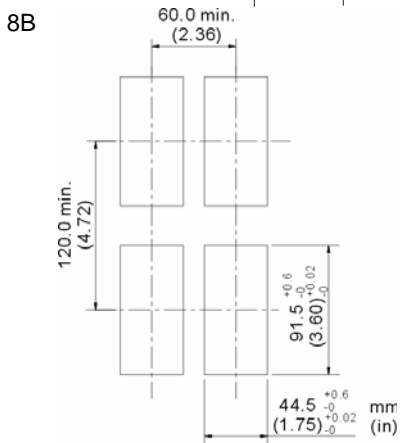
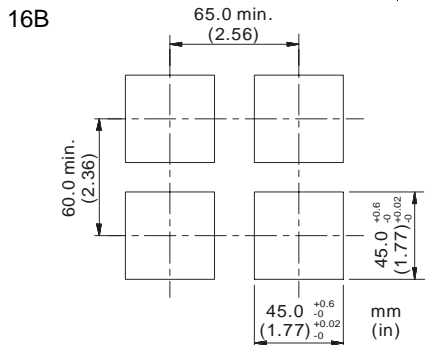
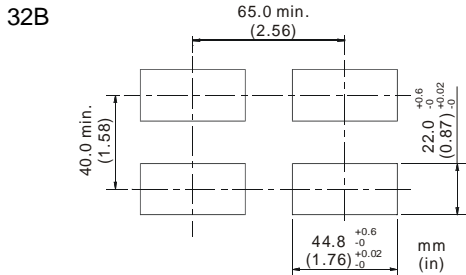

■ Terminals Identification

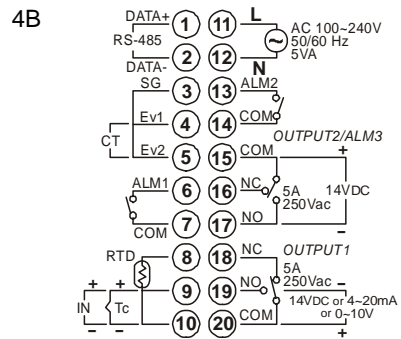
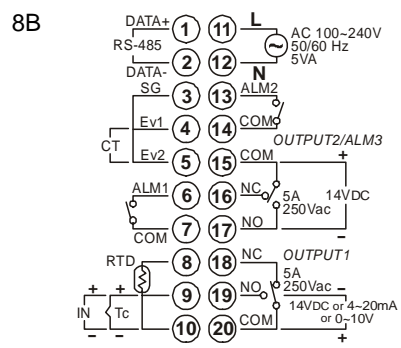
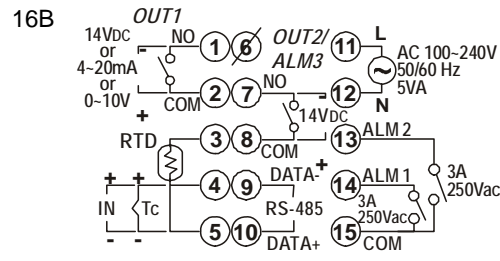
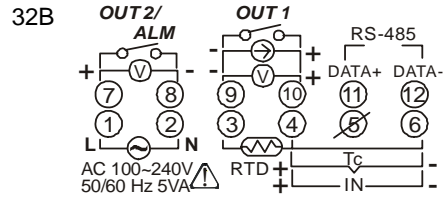

Mounting Method

- Step 1: Insert the controller through the panel cutout.
 - Step 2: Insert the mounting bracket into the mounting groove at the top and bottom of the controller.
 - Step 3: Push the mounting bracket forward until the bracket stops at panel wall.
 - Step 4: Insert and tighten screws on bracket to secure the controller in place. (The screw torque should be 0.8kgf-cm to 1.5kgf-cm)
- 16B/8B/4B Mounting Method:

Mounting Bracket Installation

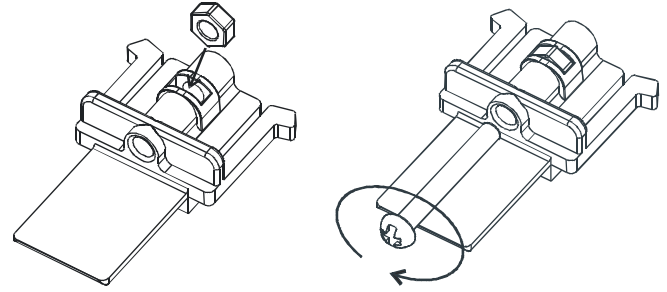

32B Mounting Method:

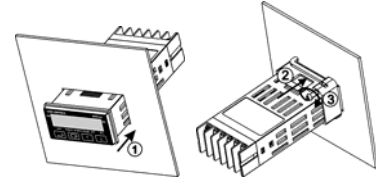
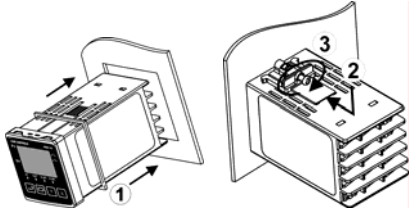

Dimensions are in millimeter (inch)

32B

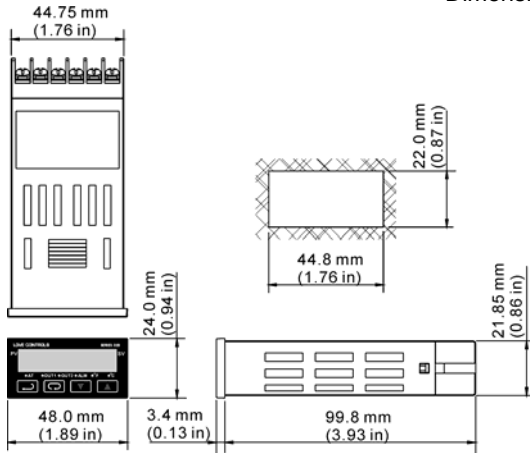

16B

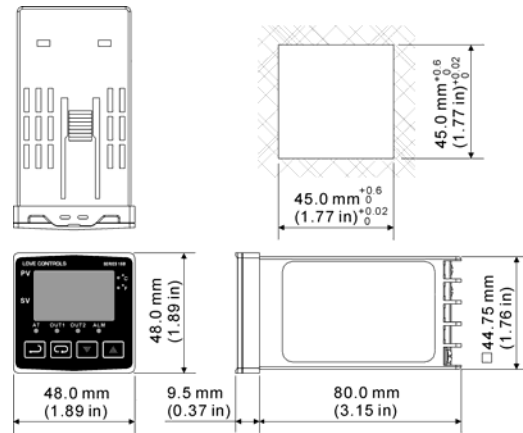

8B

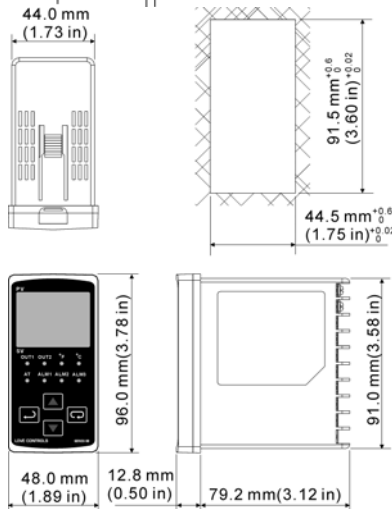

4B

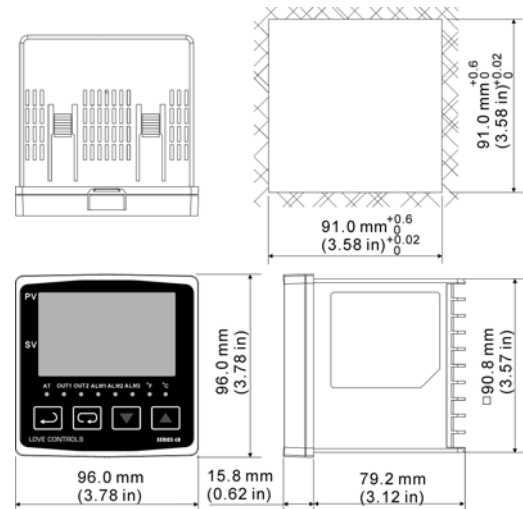

Communication error code response description:

Error Status 102EH / 4750H	PV read back 1000H / 4700H	Error status
0001H	M/A	PV unstable
0002H	8002H	Re-initial, no temperature at this time
0003H	8003H	Input sensor did not connect
0004H	8004H	Input signal error
0005H	N/A	Over input range
0006H	8006H	ADC fail
0007H	N/A	EEPROM read/write error

Display message:

	Power ON		Normal display	
PV	b 150	DTB series, Firmware V1.50	2000	Present value
SV	urE	Output VR type with Event option	00	Set value
	Sensor didn't connect		Input error	
PV	no	No	Err	Error
SV	Cont	Connect	LnPt	Input
	EEPROM error		Input over range	
PV	Err	Error	2001	PV flash when over
SV	Pron	EEPROM	00	