

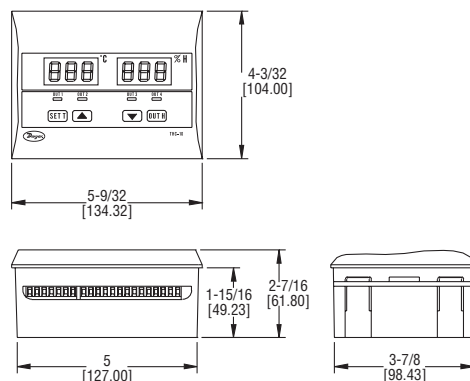

Series THC- Temperature/Humidity Switch

Specifications - Installation and Operating Instructions



Simultaneously measure and control temperature and humidity with the Series THC Temperature/Humidity Switch.

The unit offers a 3-digit red display for temperature indication and a 3-digit green display indicating humidity. The Series THC is equipped with four independent relays, two for temperature control and two relays for humidity control.

The unit offers 61 programmable parameters for temperature and humidity control including set point, differential, direct/reverse acting, cycle time, alarm clock time, and decimal point adjustment. In the event of a probe error, the default operating of the relays can be set to open or close. The THC features error or alarm messaging and password protection.

The THC Temperature/Humidity Switch accepts up to two temperature probe inputs and a humidity sensor. A humidity sensor with 0-1V, 0-3V, or 4-20mA output can be used with the Series THC.

SPECIFICATIONS

Measurement Range:

Temperature: -58 to 302°F (-50 to 150°C); **Humidity:** 0 to 100%RH.

Input: Up to 2 thermistors and 1 humidity sensor.

Output: 4 SPST, 8A relays @ 250 VAC.

Horsepower Rating (HP): 1/3 HP.

Control Type: ON/OFF direction, direct or reverse acting, neutral. Power Requirements: 110 or 230 VAC (depending on model).

Accuracy: Temperature: $\pm 0.5\%$ of probe range; Humidity: $\pm 3\%$ of range.

Display: Two 3-digit displays. 1/2" digits.

Resolution: 0.1°.

Memory Backup: Nonvolatile memory.

Ambient Operating Temperature: 32 to 158°F (0 to 70°C).

Storage Temperature: -4 to 176°F (-20 to 80°C).

Weight: 1.17 lb (530g).

Panel Cutout: 5.15" x 2.37" (131 x 111mm).

Front Panel Protection: NEMA 4X (IP65).

Agency Approvals: CE.

INTRODUCTION

Humidity and temperature control all in one unit. This unit features 2 temperature outlets and 2 humidity outlets. Separate temperature and humidity displays.

Temperature Control

3 control options are available: ON-OFF, Neutral and Refrigeration Temperature is controlled by a PTC1000 sensor and a second sensor can be added as a thermostat for defrosting time out control.

Humidity control

2 control options are available: ON-OFF and Neutral. It can use any one of 3 humidity sensors (0-1V, CRPH03, 4-20mA) all of which can be programmed by parameter.

OPERATING INSTRUCTIONS

Temperature setpoints (ST1 and ST2)

▶ Press SET and let go. Actual setpoint1 (**St1**) appears flashing.

Led **Out1** will flash indicating **St1**.

▶ Press UP or DOWN to increase or decrease setpoint value.

▶ Press SET to confirm new setpoint and actual setpoint 2 (**St2**) will appear flashing.

Led **Out2** will flash indicating it is **St2**.

▶ Press UP or DOWN to increase or decrease setpoint value.

▶ Press SET to confirm new setpoint and exit.

Setpoints for **St1** can vary between a maximum of **rt4** and a minimum of **rt6** while setpoints for **St2** can vary between a maximum of **rt5** and a minimum of **rt7**. If the setpoint desired is outside this range, change the values of **rt4**, **rt5**, **rt6** and **rt7**. Values are changed in the same manner as the other parameters.

Humidity setpoints (SH1 and SH2)

▶ Press SET H and let go. Actual setpoint 1 (**Sh1**) appears flashing.

Led **Out3** flashes indicating **Sh1**.

▶ Press UP or DOWN to increase or decrease setpoint value.

▶ Press SET H to confirm new setpoint and actual setpoint 2 (**Sh2**) will appear flashing.

Led **Out4** will flash, indicating **Sh2**.

▶ Press UP or DOWN to increase or decrease setpoint value.

- ▶ Press SET H to confirm new setpoint and exit.

Setpoints for **Sh1** can vary between a maximum of **rt4** and a minimum of **rt6** while setpoints for **Sh2** can vary between a maximum of **rt5** and a minimum of **rt7**. If the setpoints desired are outside this range, change the values of **rt4**, **rt5**, **rt6**, and **rt7**. Values are changed in the same manner as other parameters.

Temperature parameter settings

- ▶ Press SET for 8 seconds. 0 will appear flashing
- ▶ Use UP and DOWN to introduce code (default setting 0)
- ▶ Press SET to confirm. If correct, the first parameter label will appear.
- ▶ Use UP and DOWN to go to the desired parameter.
- ▶ Press SET to see actual setpoint.
- ▶ Use UP and DOWN to change to desired setpoint.
- ▶ Press SET to confirm and exit to list of parameters.
- ▶ Press SET+DOWN to exit or wait 1 minute (Keypad TIME OUT).

If after changing a parameter, you desire to go directly to 0, press SET+DOWN or 0 on remote control.

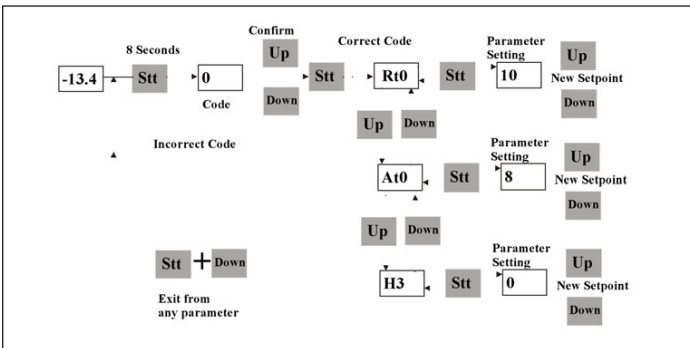

Humidity parameter settings

Follow the same steps as when adjusting temperature parameters but using the SET H key.

General parameters (H0, H1, H2, H3) can be adjusted by entering from temperature or humidity parameters.

Save default settings

- ▶ Access parameter **H0** as explained in adjusting temperature and humidity settings. 0 will appear.
- ▶ Press SET or SET H for 8 seconds. **Pro** will appear on the display if the setpoint is correct and **Epr** will appear if it is not correct.
- ▶ Press SET+DOWN or SET H+DOWN to exit or wait 1 minute (KeyPad TIME OUT).

How to visualize secondary temperature sensor

- ▶ Press SET+UP on keypad or SENSOR on remote control.

Setpoint will appear on display alternating with message indicating sensor.

Silencing alarm output

- ▶ Press UP+DOWN or CLEAR on remote control.

The alarm will reactivate after check time has run out if the state of alarm persists. For memory and sensor failures, the initial check time is 0 followed by 1 hour, once the alarm has been silenced.

Setting the keypad code to 0.

The keypad code can be set to 0 by disconnecting the unit and connecting it again to the power supply while pressing the SET key.

Keypad Protection

The keypad features a parameter which permits keypad entry blocking, so that **St1**, **St2**, **Sh1**, or **Sh2** cannot be changed. To momentarily unblock this protection, press SET for 8 seconds and introduce the code in the same way as is done when entering parameters. Press SET+DOWN and exit the parameter settings. Settings can be changed during the following 1 minute time period, even though the keypad protection is activated.

2. Display Indicators

Normal operation.

Under normal operation, the red display will show the sensor 1 temperature setpoint. The green display will show the humidity sensor.

- Led **out1** indicates relay 1
- Led **out2** indicates relay 2
- Led **out3** indicates relay 3
- Led **out4** indicates relay 4}

The furthest digit to the right on the red display flashes on receiving infrared signal.

Display flashing.

When we are introducing a new setpoint for **St1**, **St2**, **Sh1**, or **Sh2**, and when we are changing a setpoint or when the thermostat is waiting for code from the keypad, the display will flash indicating that it is waiting for confirmation of the setpoint.

If the display flashes immediately after confirmation, a memory input failure is indicated.

Led's flashing.

- ▶ Led **out1** flashes when programming **St1**.
- ▶ Led **out2** flashes when programming **St2**.
- ▶ Led **out3** flashes when programming **Sh1**.
- ▶ Led **out4** flashes when programming **Sh2**.

Error and alarm messages.

When an error or alarm message appears on the display, it is alternated with the temperature setpoint in the sensor.

- ▶ **Err** Memory reading error.
- ▶ **ErP** Error in temperature sensor that is not displayed

- ▶ **AHt** High temperature alarm for sensor 1
- ▶ **ALt** Low temperature alarm for sensor 1
- ▶ **AHH** High humidity alarm for humidity sensor
- ▶ **ALH** Low humidity alarm for humidity sensor
- ▶ **ooo** Sensor open
- ▶ **----** Short circuit in sensor

3. Temperature control process

Independent ON/OFF control

Parameter **rt8=0** and **rt0=ind**. Each relay is associated to a particular Set. **St1** controls relay 1 and **St2** controls relay 2, both for temperature sensor 1.

As an example, direct or reverse relay connection can be selected using parameter **Ct1**. In direct connection mode (**Ct1=dir**), relay 1 will connect when $TS1 \geq St1 + rt1$, with $TS1$ (temperature sensor 1) and will disconnect when $TS1 \leq St1$. **Rt1** is the differential relay for **St1** and will use different temperature setpoints to connect or disconnect relay.

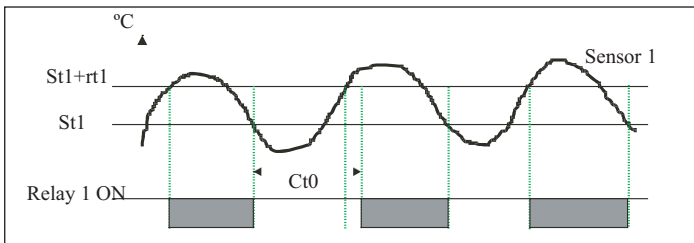

Ct0 is the time delay relay. Once disconnected, it does not connect again until **ct0** is over.

In reverse connection mode (**Ct2=inv**), relay 1 connects when $TS1 \leq St1 - rt1$ and disconnects when $TS1 \geq St1$.

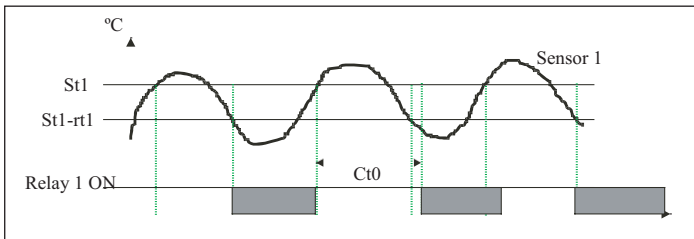

Relay 2 functions in the same manner but is controlled by setpoint **St2**, using **rt2** as the differential relay and **Ct3** as indicator of direct or reverse connection. Time delay is **Ct1**.

Dependent ON/OFF control.

Parameter **rt8 = ON** and **rt0 = dep**. In this case, relay 1 association is the same as in the previous case, but relay 2 uses the sum of **St1** and **St2** setpoints, instead of only using the **St2** setpoint.

In direct connection mode (**Ct3 = dir**), relay 2 connects when $TS1 \geq (St1 + St2) + rt2$, for $TS1$ (temperature sensor 1) and disconnects when $TS1 \leq (St1 + St2)$.

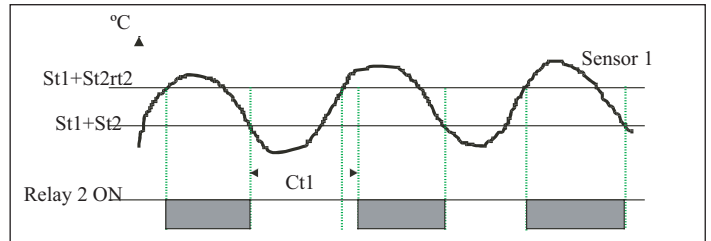

In reverse connection mode (**Ct3 = inv**) relay 2 connects when $TS1 \leq St1 + St2 - rt2$ and disconnects when $TS1 \geq (St1 + St2)$.

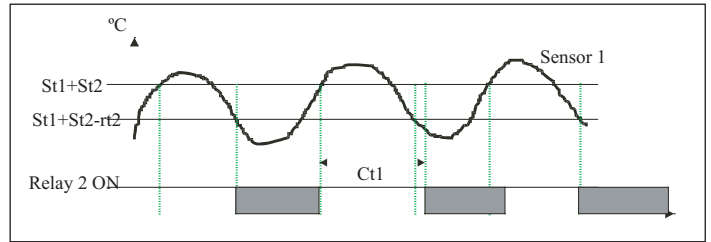

Cooling control

Parameter **r8 = Ref**. Temperature can be adjusted using relay 1 and sensor 1, while defrosting is triggered by relay 2.

Adjusting settings

Settings depend on **St1** value. The compressor switches on when $TS1 \geq St1 + rt1$, for $TS1$ (environment temperature sensor) and switches off when $TS1 \leq St1$. **Rt1** is the differential relay and will use different temperature setpoints to switch the compressor on or off.

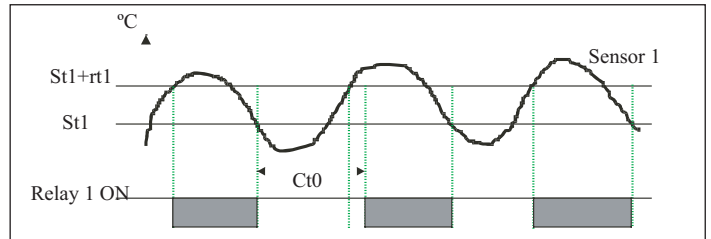

Defrosting

Three defrosting methods are available.

- ▶ Switching off the compressor. The defrosting relay is disconnected.
- ▶ Switching off the compressor and connecting a heat resistor to the defrosting relay.
- ▶ Switching on the compressor and connecting an electro-valve to the defrosting relay to reverse the cycle.

To choose the type of defrosting desired. For the first two options, **dt0 = re** and for the third **dt0 = in**.

Defrosting should be carried out at time periods indicated by **dt3**. If **dt3** is zero, defrosting will not be carried out periodically. First defrosting will occur one **dt3** period after starting up.

Defrosting can be activated and deactivated from the keypad. When defrosting is activated from the keypad, the instructions are introduced between previous programming.

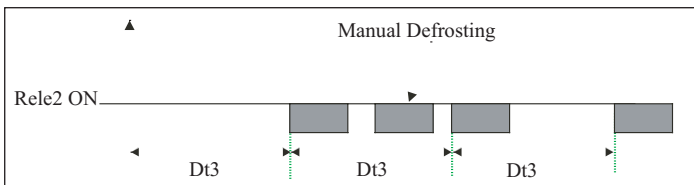

Defrosting cannot be activated if:

- ▶ A continuous cold cycle is activated.
- ▶ Unit is in auxiliary adjustment mode (due to memory failure).
- ▶ Defrosting is already activated.
- ▶ $TS2 \geq dt1$.
- ▶ Maximum defrosting time $dt2$ is zero.

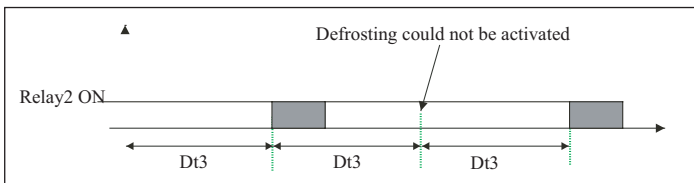

Defrosting is deactivated when:

- ▶ $Dt1$ temperature is reached.
 - ▶ Maximum defrosting time $dt2$ is reached.
 - ▶ An end defrost order is received from the keypad or remote control.
- During and after defrosting, initial defrosting temperature can be displayed if desired by selecting this option with $dt4$. This option is available as long as initial defrosting temperature has not been reached, or an hour has gone by since deactivation.

Continuous cold cycle

A continuous cold cycle. This maintains the compressor in operation for a period of time $ct6$. These cycles are activated from the keypad and end when the time period is finished or an order is given from the keypad.

The cycle will not commence if:

- ▶ Unit is in heat adjusting mode.
- ▶ Unit is in auxiliary adjusting mode (due to memory failure).
- ▶ Defrosting is activated.

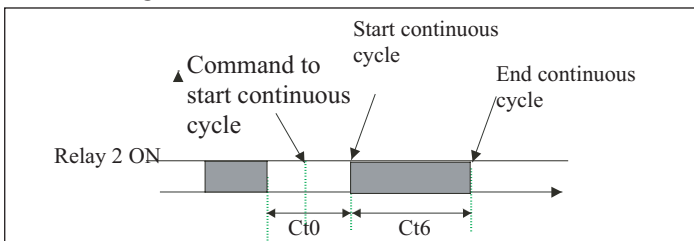

Neutral Zone Control

Parameter $rt8 = NEu$. Adjustment is associated to $St1$ for temperature sensor 1 (TS1). When $TS1 \geq St1 + rt3$, relay 1 connects and does not disconnect until $TS1 \leq St1$. When $TS1 \leq St1 - rt3$, relay 2 connects and does not disconnect until $TS1 \geq St1$.

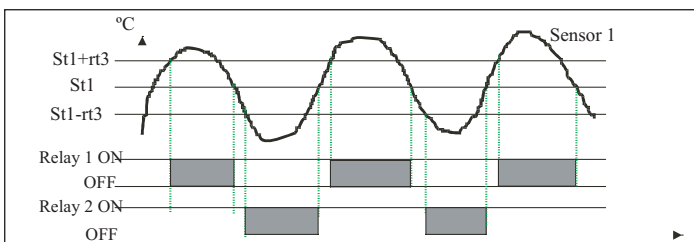

Sensor 2 failure

This will only affect the defrost function. In this case the sensor value is used only to determine how long defrost has been in progress, not when it ends.

Sensor 1 failure

Relays will remain connected, as indicated in parameters $Ct4$ and $Ct5$. If $Ct4 = oPn$, relay 1 will remain open, but if $Ct4 = Clo$, it will remain closed. The same applies to relay 2 with parameter $Ct5$. ON/OFF2 mode will only affect relay 2, which will remain as indicated in $Ct5$.

Temperature alarms

If $TS1 \geq St1 + At1$, the thermostat will indicate maximum temperature alarm for sensor 1 (Aht) and the alarm will remain activated until temperature $TS1 \leq St1 + (At1 - At0)$.

If $TS1 \leq St1 - At3$, the thermostat will activate minimum temperature alarm for sensor 1 (Alt), and it will remain activated until temperature $TS1 \geq St1 - (At3 - At0)$ (TS1 temperature sensor 1)

Program $At3$ to indicate the time lapse between alarm event and indication of an alarm event. $At3$ is therefore the alarm check time. The alarm is indicated by a message on the display and activating the alarm output if there is one.

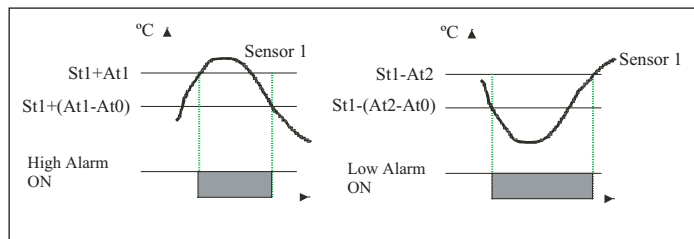

Other Options.

St1 and St2 range limits

$St1$ or setpoint 1 can only range between $rt4$ as minimum and $rt6$ as maximum.

$St2$ or setpoint 2 can only range between $rt5$ minimum and $rt7$ maximum.

Temperature range

$Pt2$ allows for Celsius or Fahrenheit temperature reading.

Sensor calibration

Add the value of $Pt0$ to the calculated value of sensor 1. The result is the value the thermostat will work with and display as sensor 1 value.

Decimal point.

Parameter $Pt1$ allows for introducing or deleting decimal points on display. Parameters will always include decimal points.

Number of sensors.

$Pt3$ allows for choosing 1 or 2 sensors.

4. Humidity control process

Independent ON/OFF control.

Parameter **rh8** = ON and **rh0** = ind. The adjustment of each relay is carried out in association with a given Set. Relay 3 is associated with **Sh1** and relay 4 is associated with **Sh2** for humidity sensor 3.

As an example, we can choose between direct or reverse connection for relay 3 by using parameter Ch1. In direct connection mode (**Ch1** = dir), relay 1 will connect when $HS3 \geq Sh1 + rh1$, with HS3 (humidity sensor 3) and will disconnect when $HS3 \leq Sh1$. Rh1 is the differential relay for **Sh1** and it will use different humidity setpoints to connect and disconnect the relay.

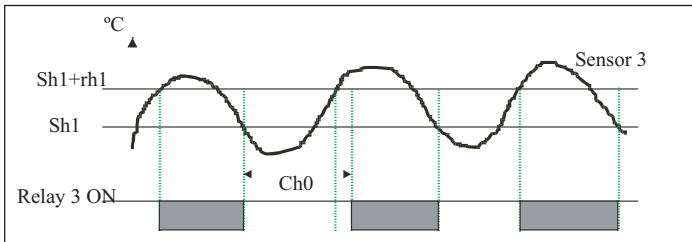

Ch0 is the time delay relay. Once it disconnects, it does not connect again until **ch0** is over.

In reverse connection mode (**Ch2** = inv), relay 3 connects when $HS3 \leq Sh1 - rh1$ and disconnects when $HS3 \geq Sh1$.

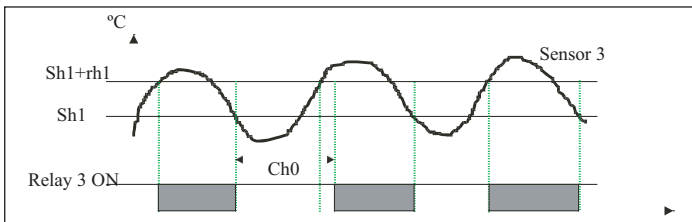

Relay 4 functions in the same manner, but is controlled by setpoint **Sh2**, using **rh2** as the differential relay and **Ch3** as indicator of direct or reversed connection. Time delay is **Ch1**.

Dependent ON/OFF control.

Parameter **rh8** = ON and **rh0** = dep. In this case, relay 1 association is the same as in the previous case, but relay 4 uses the sum of setpoints **St1** and **St2** instead of only using setpoint **Sh2**.

In direct connection mode (**Ch3** = dir) relay 4 connects when $HS3 \geq (Sh1 + Sh2) + rh2$, with HS3 (humidity sensor 3) and disconnects when $HS3 \leq (Sh1 + Sh2)$.

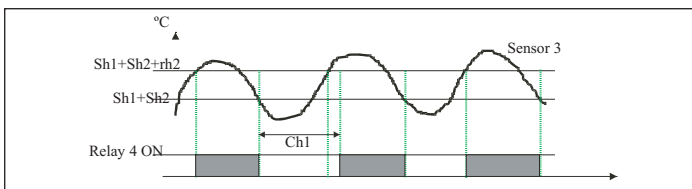

In reverse connection mode (**Ch3** = inv) relay 4 connects when $HS3 \leq Sh1 + Sh2 - rh2$ and disconnects when $HS3 \geq (Sh1 + Sh2)$.

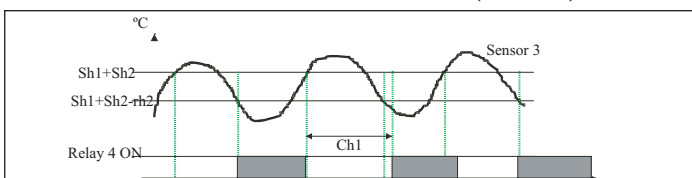

Neutral zone control

Parameter **rh8** = Neu. Adjustment is carried out in association with **Sh1** and with humidity sensor 3 (HS3). When $HS3 \geq Sh1 + rh3$, relay 3 connects, and does not disconnect until $HS3 \leq Sh1$. When $HS3 \leq Sh1 - rh3$, relay 4 connects and does not disconnect until $HS3 \geq Sh1$.

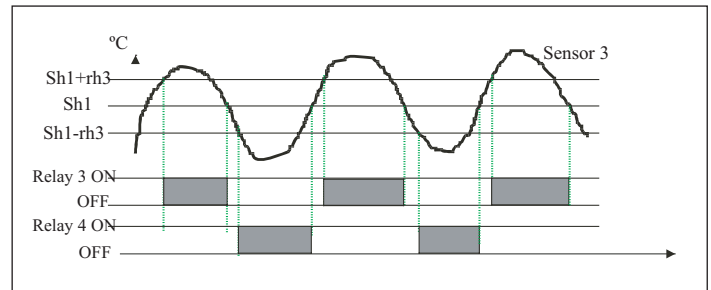

Sensor 3 failure

Relays will remain connected, as indicated in parameters **Ch4** and **Ch5**. If **Ch4** = oPn, relay 3 will remain open, and if **Ch4** = Clo, it will remain closed. The same applies for relay 4 with parameter **Ch5**.

Humidity alarms.

If $HS3 \geq Sh1 + Ah1$, the thermostat will indicate maximum humidity alarm for sensor 3 (**AHH**) and the alarm will remain active until $HS3 \leq Sh1 + (Ah1 - Ah0)$. If $HS3 \leq Sh1 - Ah3$, the thermostat will indicate minimum humidity alarm for sensor 3 (**ALH**) and the alarm will remain active until $HS3 \geq Sh3 - (Ah3 - Ah0)$. (HS3 humidity sensor 3).

Program **Ah3** to indicate the time lapse between alarm event and indication of alarm event. Ah3 is therefore the alarm time check. Alarm is indicated by a display message and activating the alarm output if there is one.

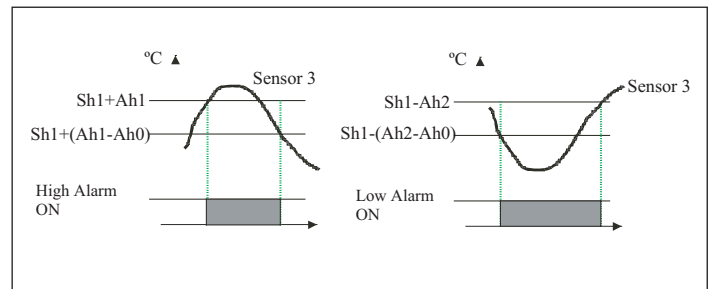

Other options.

Sh1 and Sh2 range limits.

Sh1 or humidity setpoint 1 can only be set between minimum value **rh4** and maximum value **rh6**. **Sh2** or humidity setpoint 2 can only be set between minimum value **rh5** and maximum value **rh7**.

Calibrating the sensors.

The value of **Ph0** must be added to the calculated value of sensor 3. The result is the value of sensor 3, which the thermostat works with and displays.

Decimal point

Program **Ph1** to indicate whether you want to display sensor readings with or without decimal points. Parameters will always have decimal points.

Humidity sensor type

Ph2 allows a choice of 3 types of humidity sensors.

▶ **IV:** 0-1 volt output sensor, with 0V = 0%H and 1V = 100%H.

▶ **3V:** Electric sensor with 0-3 Volt output.

▶ **420:** 4-20 mA sensor. Use **Ph3** and **Ph4** to choose this sensor. **Ph3** for humidity value for 4mA and **Ph4** for humidity value for 20mA.

TECHNICAL CHARACTERISTICS

Power Supply	230 VAC
Mounting	imbedded in 120 x 100mm opening with 60 mm depth
Range of Operation	0 °C to 70 °C
Storage	-20 °C to 80 °C
Sensor Range	Temperature -50.0°C to 150°C Humidity 0-100%
Accuracy	Best at 0.5% from bottom of scale
Resolution	±0.1 °C
Display	(2) 3 digit displays plus sign
Sensors	Temperature: PTC models CRPTC05, CRPTC20 Humidity: 0-1V, CRPH03, 4-20mA
Inlets	-Temperature sensor 1 -Temperature sensor 2 -Humidity sensor 3
Outlets	▶ Relay 1 SPDT I _{max} =8A res. (3A ind.) Vac max=250V ▶ Relay 2 SPST I _{max} =8A res. (3A ind.) Vac max=250V ▶ Relay 1 SPDT I _{max} =8A res. (3A ind.) Vac max=250V ▶ Relay 2 SPST I _{max} =8A res. (3A ind.) Vac max=250V
Connections	Screw terminals for 1.5mm ² maximum section wire leads
Communication	RS232 Compatible
Operation	Keypad or infrared remote control (ref. CRIR)
Front Protection	IP65

WIRING DIAGRAM

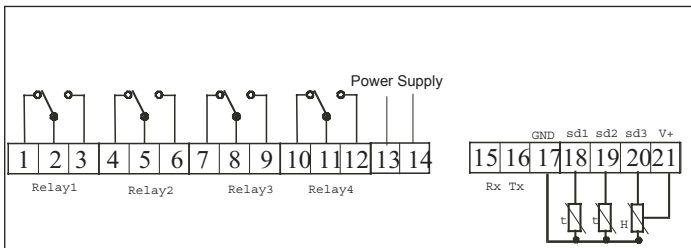

GENERAL OPTIONS

1. Keypad protection

Use **H1** to block **Set1** and **Set2** ranges. This option is only available for the thermostat keypad, and not for the remote control.

2. Communication set-up

Parameter **H2**. Enter communications settings here.

3. Keypad code.

Parameter **H3**. This code must be introduced in order to change parameters. This code can be set to zero when starting up if Set key is pressed at the same time.

4. Memory failure.

If a memory failure occurs, the thermostat will leave all the relays open

5. Alarms caused by sensor or memory failures

As soon as sensor1, sensor2 or sensor3 fail, a display message will indicate an alarm. Press UP+DOWN to erase message. If the situation remains unchanged one hour later, the message will reappear.

6. Parameter list

Parameters are divided into temperature parameters and humidity parameters. There are 4 general parameters (H0 to H3) which are the same for both charts.

7. Temperature Parameters

Parameters	Units	Field	Setting H0=0
St1 Temperature setpoint 1	degrees	rt4 to rt6	10.0
St2 Temperature setpoint 2	degrees	rt5 to rt7	10.0
rt0 St1 and St2	range	ind/dep	ind
rt1 St1 differential	degrees	0.1 a 20.0	1.0
rt2 St2 differential	degrees	0.1 to 20.0	1.0
rt3 Band differential	degrees	0.1 to 20.0	1.0
rt4 Minimum value St1 setting	degrees	-99.9 to rt6	-99.9
rt5 Minimum value St2 setting	degrees	-99.9 to rt7	-99.9
rt6 Maximum value St1 setting	degrees	rt4 to 302	99.9
rt7 Maximum value St2 setting	degrees	rt5 to 302	99.9
rt8 Setting/Operation Mode	range	ON/REF/nEU	ON1
At0 Alarm differentials	degrees	0.1 to 20.0	0.1
At1 Maximum sensor 1 (1) alarm	degrees	0.1 to 99.9	99.9
At2 Minimum sensor 1 (1) alarm	degrees	0.1 to 99.9	99.9
At3 Alarm check time	h-m	0.0 to 18.0	18.0
ct0 Minimum shut down time relay 1	minutes	0 to 240	0
ct1 Minimum shut down time relay 2	minutes	0 to 240	0
ct2 Operation relay 1	range	dir/inv	dir
ct3 Operation relay 2	range	dir/inv	dir
ct4 Default operation relay 1	range	OPn/Clo	OPn
ct5 Default operation relay 2	range	OPn/Clo	OPn
ct6 Continuous cycle time	minutes	0 to 240	0
Pt0 Sensor calibration 1	degrees	-20.0 to 20.0	0.0
Pt1 Decimal points	range	no/yes	ues
Pt2 Temperature scale °C or °F	range	°C/°F	°C
Pt3 Number of sensors	range	--	2
Pt2 Sensor Type	range	1V/3V/420	3V
H0 Select save settings	range	0	0
H1 Keypad protection	range	no/yes	no
H4 Communication set-up	norm	0 to 999	--
H5 Keypad code	norm	0 to 999	--

8. Humidity Parameters

Parameters	Units	Field	Setting H0=0
Sh1 Humidity setpoint 1	%H	rh4 to rh6	50.0
Sh2 Humidity setpoint 2	%H	rh5 to rh7	50.0
rh0 Dependence between St1 and St2	range	ind/dep	ind
rh1 Sh1 differential	%H	0.1 to 20.0	1.0
rh2 Sh2 differential	%H	0.1 to 20.0	1.0
rh3 Band differential	%H	0.1 to 20.0	1.0
rh4 Minimum value St1 setting	%H	0 to rt6	0
rh5 Minimum value St1 setting	%H	0 to rt7	0
rh6 Maximum value St1 setting	%H	rh4 to 100	100
rh7 Maximum value St2 setting	%H	rh5 to 100	100
rh8 Setting/Operation Mode	range	ON/nEU	ON
Ah0 Alarms differential	%H	0.1 to 20.0	0.1
Ah1 Maximum sensor value 1 (1) alarm	%H	0.1 to 99.9	99.9
Ah2 Minimum sensor value 1 (1) alarm	%H	0.1 to 99.9	99.9
Ah3 Alarm check time	h-m	0.0 to 18.0	18.0
ch0 Minimum shut down time relay 3	minutes	0 to 240	0
ch1 Minimum shut down time relay 4	minutes	0 to 240	0
ch2 Operation relay 3	range	dir/inv	dir
ch3 Operation relay 4	range	dir/inv	dir
ch4 Default operation relay 3	range	OPn/Clo	OPn
ch5 Default operation relay 4	range	OPn/Clo	OPn
Ph0 Sensor calibrating 1	%H	-20.0 to 20.0	0.0
Ph1 Decimal points	range	no/yes	yes
Pt2 Sensor type	range	1V/3V/420	3V
Pt3 Value for 4 mA	range	0 to 100	0
Pt4 Value for 20 mA	range	0 to 100	100
H0 Select save settings	range	0	0
H1 Keypad protection	range	no/yes	no
H4 Communications set-up	norm	0 to 999	--
H5 Keypad code	norm	0 to 999	--