

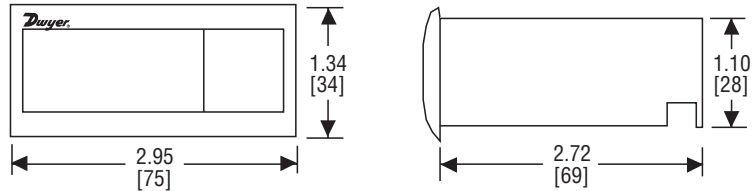

TSS Series Dual Stage Temperature Switch

Specifications and Operating Instructions



Panel Cutout 2-51/64 x 1-9/64 (71 x 29)

DESCRIPTION

Regulate temperatures for heating or cooling control with Series TSS Dual Stage Temperature Switch. The Series TSS is designed to accept two inputs (thermistor or RTD) with independent 8 A relay output for dual stage temperature control. The unit also features a 30 mA TTL alarm output for activating an external buzzer.

The Series TSS offers 34 programmable parameters to customize control functions. Access to all parameters, except setpoint, can be secured with a password code. The TSS Series includes a rear terminal cover, and instruction manual. Input sensors are sold independently.

INSTALLATION

NOTE: Unit must be mounted away from vibration, impacts, water, and corrosive gases.

- Cut hole in panel 71 x 29mm (2.8 x 1.14 inches).
- Apply silicone (or rubber gasket) around the perimeter of the hole to prevent leakage.
- Insert unit into hole of panel.
- Slide removable fitting clips onto unit from the back until secure to panel.
- Remove back cover to wire unit.
- Wiring diagram is displayed on the top of the unit.
Temperature Probe 1 (Sd1) in terminals 7-9
Temperature Probe 2 (Sd2) in terminals 7-8
- Note: DO NOT INSTALL PROBE CABLES NEAR POWER CABLES.
- Replace cover once wiring is complete.

SPECIFICATIONS

Probe Range: -58 to 302°F (-50°C to 150°C).

Input: PTC thermistor (1000Ω @ 25°C), or RTD (PT100Ω @ 0°C).

Outputs: One 8A SPDT relay @ 250VAC, resistive; One 8A SPST relay @ 250VAC resistive; Alarm: TTL 30mA @ 12VDC.

Horsepower Rating (HP): 1/3 HP.

Power Requirements: 12 VAC/DC.

Accuracy: 0.5% of full scale.

Display: 3-digit and sign, red.

Resolution: 0.1° (3 digits).

Memory Backup: Nonvolatile memory.

Ambient Operating Temperature: 32 to 158°F (0°C to 70°C).

Storage Temperature: -4 to 176°F (-20°C to 80°C).

Dimensions: 76 x 34 x 60 mm (3 x 1.3 x 2.4in).

Front Panel Rating: NEMA 4X (IP65).

Weight: 2.3 oz (65 g).

Agency Approvals: CE, UR.

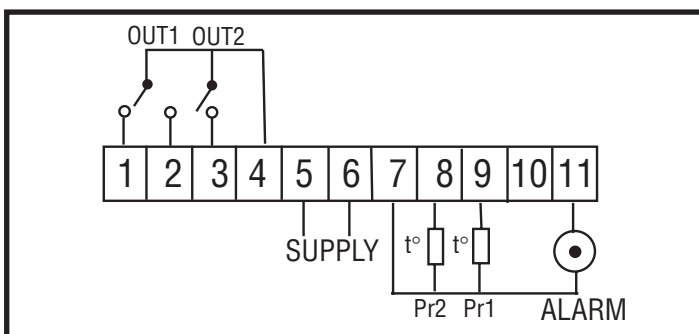

PARAMETERS

Description

	Units	Range
Set 1	Degrees	r4 to r6
Set 2	Degrees	r5 to r7
r0	Range	Ind/Dep
r1	Degrees	0.1 to 20.0
r2	Degrees	0.1 to 20.0
r3	Degrees	0.1 to 20.0
r4	Degrees	-99.9 to r6
r5	Degrees	-99.9 to r7
r6	Degrees	r4 to 302
r7	Degrees	r5 to 302
r8	Range	On1/On2/nEU
A0	Degrees	0.1 to 20.0
A1	Degrees	0.1 to 99.9
A2	Degrees	0.1 to 99.9
A3	Degrees	0.1 to 99.9
A4	Degrees	0.1 to 99.9
A5	hh:m	0.0 to 18.0
c0	Minutes	0 to 240
c1	Range	dir/Inv
c2	Range	dir/Inv
c3	% ON	0 to 100
c4	% ON	0 to 100
P0	Range	°C/°F
P1	Degrees	-20.0 to 20.0
P2	Degrees	-20.0 to 20.0
P3	Option	no/yes
P4	Option	sd1/sd2
P5	Range	1/2
H0	Command	0
H1	Option	no/yes
H2	Option	dir/inv
H3	Option	dir/inv
H4	Numeric	0 to 999
H5	Numeric	0 to 999
H6	Option	ptc/pt1

(*) Time format: hh:m, where "m" are tenths of minutes.

TEMPERATURE PARAMETER PROGRAMMING

Set Points (Set 1, Set 2) are the only parameters the user can access without code protection.

- Press SET. Current value of Set 1 appears flashing and LED OUT flashes.
- The value can be modified with the UP and DOWN arrows.
- Press SET again to confirm Set 1. Current value of Set 2 appears flashing and LED DEF flashes.
- The value can be modified with the UP and DOWN arrows.
- Press SET to enter Set 2 value and exit.

Access to all code protected parameters

- Press SET for 8 sec. The access code value 0 is shown on the display (unit comes with codes set at 0 from factory).
- Select the correct code with the UP and DOWN arrows.
- Press SET to enter the code. If the code is correct, the first parameter label is shown on the display (Set 1)
- Move to the desired parameter with the UP and DOWN.
- Press SET to view the value on the display.
- The value can be modified with the UP and DOWN arrows.
- Press SET to enter the value.
- Repeat until all necessary parameters are modified.
- Press SET and DOWN at the same time to quit programming or wait one minute and the display will automatically exit programming mode.

*The keyboard code can be reset to ZERO by turning off the controller and turning it on again while keeping the SET key depressed.

Set default settings

- Access parameter H0 as explained 0 will appear
- Press SET for 8 seconds. Pro will appear on the display if the Set Point is correct, and Epr will appear if it is not correct.
- Press SET + DOWN to exit or wait 1 minute.

TEMPERATURE CONTROL PROCESS

Independent ON/OFF control (1 probe)

If r8=ON1 and r0=Ind, each output is associated to a particular Setpoint.

If c1=dir, output 1 will connect when $TS1 \geq Set1 + r1$ (where TS1 is the temperature of probe 1) and will disconnect when $TS1 \leq Set1$.

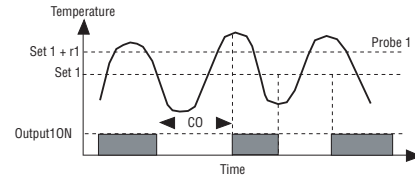

c0 is the minimum stop time. Once the output is disconnected, it is not connected again until c0 minutes later.

If c1=Inv, output 1 will connect when $TS1 \leq Set1 - r1$ and will disconnect when $TS1 \geq Set1$.

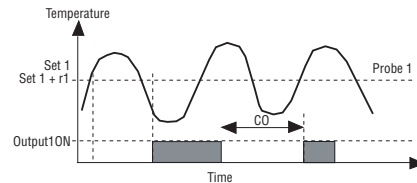

The output 2 is handled in the same manner but controlled by Set 2, using r2 as differential, c2 as indicator of direct or reverse connection, and c0 as minimum stop time.

Dependent ON/OFF control (1 probe)

If r8=ON1 and r0=Dep, output 1 works as an independent ON/OFF control, but output 2 works as follows:

If c2=dir, output 2 will connect when $TS1 \geq Set1 + Set2 + r2$ (where TS1 is the temperature of probe 1) and will disconnect when $TS1 \leq Set1 + Set2$.

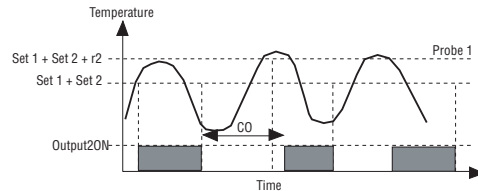

c0 is the minimum stop time.

If c2=Inv, output 2 will connect when $TS1 \leq Set1 + Set2 + r2$ and will disconnect when $TS1 \geq Set1 + Set2$.

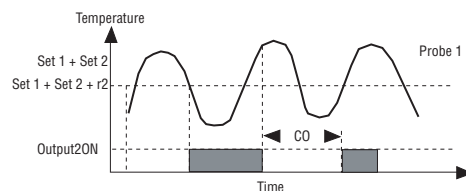

- Two Regulations (2 probes):

If r8=ON2, output 1 works as an independent ON/OFF control, and output 2 also works as an independent control. Parameter r0 is voided.

Neutral Zone Control

If r8=NEu output 1 connects when $TS1 \geq \text{Set 1} + r3$ and disconnect when $TS1 \leq \text{Set 1}$, while output 2 connects when $TS1 \leq \text{Set 1} - r3$ and disconnects when $TS1 \geq \text{Set 1}$.

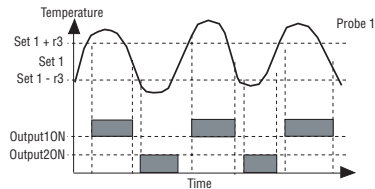

Control with probe errors

If reading of probe 1 fails, the output 1 works following 10 minute cycles, with a percentage of connection time given by c3. Output 2 is carried out in the same way with parameter c4.

Temperature alarms

If $TS1 \geq \text{Set 1} + A1$, the thermostat will indicate maximum temperature alarm for probe 1 (Ah) and the alarm will remain activated until temperature $TS1 \leq \text{Set 1} + A1 - A0$.

If $TS1 \leq \text{Set 1} - A3$, the thermostat will activate minimum temperature alarm for probe 1 (AL), and it will remain activated until temperature $TS1 \geq \text{Set 1} - A3 - A0$.

In the same way for probe 2 (TS2) with A2 an A4.

Setup A5 to indicate the alarm check time between alarm event and indication of an alarm event. The alarm is indicated by a message on the display and activating the alarm output if present (alarm can be silenced pressing SET + DOWN keys or CLEAR in the remote control).



Probe options

Set P3 to select if the decimal point is shown or not in the display.

Set P0 to set temperature units (Celsius or Fahrenheit).

If the probe is not placed in the exact point to control, use a standard thermometer to determine the offset and set it by P1 (for probe 1) and P2 (for probe 2).

Set P5 to select if 1 or 2 temperature probes are used.

GENERAL PARAMETERS

H1, H4, H4 general parameters

Setting H1 to YES, the set points (Set 1, Set 2) cannot be changed. To unblock this protection, press SET for 8 seconds and introduce the code in the same way as is done when entering parameters.

H4 sets the communication address for the controller.

H5 sets the access code to parameters.

LED INDICATION AND DISPLAY MESSAGES

OUT LED indicates relay 1 ON or OFF depending on parameter H2. IF H2=dir, when relay 1 is ON LED is ON; and if H2=rev, when relay 1 is ON, LED is OFF.

Def LED indicates relay 2 ON or OFF depending on parameter H3, as previous one.

In normal operation, the display will show the temperature measure by probe selected by P4 parameter. In order to display the temperature measured by the other probe, press SET + UP keys.

In case of alarm error, the following messages can be shown:

- Err =Memory reading error
- ErP =Error in probe not shown on display
- AH1 =High temperature alarm (probe 1)
- AL1 =Low temperature alarm (probe 2)
- AH2 =High temperature alarm (probe 1)
- AL2 =Low temperature alarm (probe 2)
- ooo =Open probe error
- =Short circuit probe error

MAINTENANCE, CLEANING, AND REPAIR

After final installation of the unit, no routine maintenance is required.

Clean the surface of the display controller with a soft and damp cloth. Never use abrasive detergents, petrol, alcohol, or other solvents.

All repairs must be made by authorized personnel.

LOVE CONTROLS DIVISION
DWYER INSTRUMENTS, INC.
P.O. BOX 373 • MICHIGAN CITY, INDIANA 46361, U.S.A.

Phone: 219/879-8000
Fax: 219/872-9057

www.love-controls.com
e-mail: love@love-controls.com