



## Model UPT 1000 – Universal Process-Temperature Indicator

### Specifications - Installation and Operating Instructions



#### PHYSICAL DATA

**Selectable Inputs:** Thermocouple, RTD, DC Voltage, or DC current.

**Input Impedance:** Thermocouple = 3 megohms, Current = 10 ohms, Voltage = 5000 ohms.

**RTD Excitation Current:** 200 $\mu$ A.

**Display:** Two 4-1/2 digit LCD.

**Accuracy:**  $\pm 0.25\%$  of span;  $\pm 1$  least significant digit.

**Maximum Overload:** Current = 110mA, Voltage = 25Vdc.

**Resolution:** 1 count, 1 degree or 0.1 degree selectable.

**Drift Over Temperature:**  $\pm 0.02\%$  (200 ppm) per  $^{\circ}$ C typical,  $\pm 0.05\%$  (500 ppm) maximum.

**Memory Backup:** Non-Volatile EEprom.

**Response Time:** 2 readings per second.

**Operating Temperature:** 32 to 104 $^{\circ}$ F (0 to 40 $^{\circ}$ C).

**Humidity Conditions:** 0 to 40% Non-Condensing.

**Power:** 9V battery.

**Battery Life:** 200 hours typical.

**Case Material:** Anodized Aluminum with Plastic end caps.

**Dimensions:** 6.8"L x 2.8"W x 0.9"D (172.7 x 71 x 22.9 mm).

#### Introduction

The Love Controls **UPT 1000 Digital Hand-Held Universal Process/Temperature Indicator** is a microprocessor based precision general-purpose thermometer and process indicator designed for use with a multitude of standard inputs. These inputs include Type J, K, T, E, R, S, B, and N Thermocouples as well as 100 $\Omega$  2/3-wire Platinum, 120 $\Omega$  Nickel, and 1000 $\Omega$  Platinum RTDs.

In addition to these temperature inputs the UPT 1000 is capable of measuring current inputs (4-20 mA dc) and voltage inputs (0 – 10 Vdc) making it an ideal instrument for calibrating and validating a variety of process instruments.

Standard features include: Standard ANSI mini-jack connector or removable screw terminal type plug, peak/valley indication, full degree or tenth of a degree resolution in both Fahrenheit or Celsius as well as an impressive set of fully scalable user selectable engineering units, 20 minute auto power-off to conserve battery life (can be disabled), and backlight.

The Love Controls UPT 1000 is a class leading hand-held indicator offering 0.25% full-scale accuracy over thirteen common input ranges. The unit is packaged in a sturdy extruded aluminum case that will help to ensure years of service and dependability. The UPT 1000 is designed and manufactured in the USA and carries a 1-year limited warranty.

Also available are a soft carrying case (L402-A), extra screw type connectors (part No. 481-0199) and a variety of ANSI connectors and handheld temperature probes, offered in both kits or individually.

#### NOTE:

This instrument is shipped with a new 9V battery. However, there is a protective plastic cap installed on the battery terminals. This cap must be removed and the battery connected to the battery terminal before the instrument will function. Use only 9 Volt alkaline type batteries such as Duracell<sup>®</sup> MN1604, or Eveready<sup>®</sup> 522, or equivalent. Zinc-carbon types, often labeled Heavy-Duty are not recommended because of their shorter life and increased potential for leakage. Alkaline batteries are a better value because they typically last up to three times longer in this device. For battery installation see page 4.

#### Low Battery Indication

When the 9V battery is reaching the end of its life, the "LOW BAT" indicator on the display will turn on.

Duracell<sup>®</sup> is a registered trademark of Duracell USA, a division of Duracell Inc.  
Eveready<sup>®</sup> is a registered trademark of Eveready Battery Company Inc.

**LOVE CONTROLS Division**

DWYER INSTRUMENTS, INC. • P.O. BOX 338  
MICHIGAN CITY, INDIANA 46361-0338, U.S.A.

Phone: 800/828-4588 or 219/879-8000

websites: [www.love-controls.com](http://www.love-controls.com) or [www.dwyer-inst.com](http://www.dwyer-inst.com)

Fax: 219/872-9057

e-mail: [info@dwyer-inst.com](mailto:info@dwyer-inst.com)

Lit-By Fax: 888/891-4963

## Input Wiring

Thermocouples and RTD's with mini plugs can plug directly into the mini jack on the top of the instrument. Thermocouples and RTD's with stripped wire ends, and current or voltage inputs can wire into the removable plug.

- 3 wire RTD's with mini plugs – Plugs into three terminal mini jack.
- 2 wire RTD's with mini plugs – Plug into two of the three terminals of the three terminal mini jack. Align the large terminal of the plug with the large terminal of the jack. **Place a jumper wire between terminals 2 and 3 of the removable plug.**

Thermocouples with mini plugs – Plug into two of the three terminals of the three terminal mini jack. Align the large terminal of the plug with the large terminal of the jack.

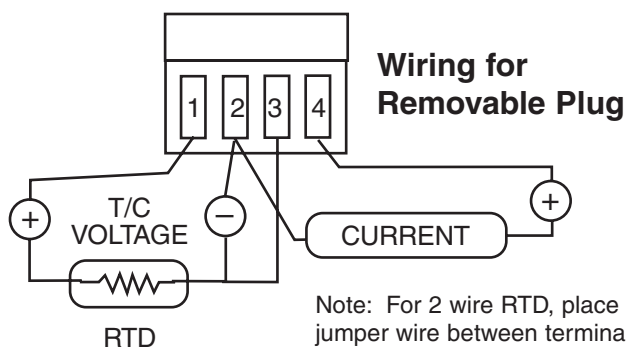

## Input Ranges (Field Selectable) Thermocouple Types

Input Type	Type J or L* Iron Constantan	Type K* Chromel-Alumel	Type T* Copper-Constantan	Type E* Chromel-Constantan
Range				
1°F	-100 to +1607	-200 to +2500	-350 to +750	-100 to +1800
1°C	-73 to +875	-129 to +1371	-212 to +398	-73 to +982

Input Type	Type R PT 13%-PT	Type S PT 10%-PT	Type B PT 6% RE-PT 30% RE	Type N* Ni Chr Si-Ni Si
Range				
1°F	0 to +3200	0 to +3200	+75 to +3276	-100 to +2372
1°C	-17 to +1760	-17 to +1760	+24 to +1802	-73 to +1300

\* These Input Types can be set for 0.1° display. If temperature goes above 1999.9° the display will return to whole degree resolution. The display will revert to 0.1° when the temperature falls back below 2000°.

## RTD Types

Input Type	100 Ohm Platinum 0.00385 DIN Curve*	120 Ohm Nickel 0.00628 US Ind. Curve*	100 Ohm Platinum 0.00385 DIN Curve*
Range			
1°F	-328 to +1607	-112 to +608	-328 to +1607
1°C	-200 to +875	-80 to +320	-200 to +875

## Process Input Types

The 0-20 mAdc and 0-10 Vdc inputs are fully scalable with a maximum of 32000 counts span placed anywhere within the range of -19999 to +19999. Decimal point position is adjustable from zero place (19999), tenths (1999.9), hundredths (199.99), thousandths (19.999) or ten thousandths (1.9999).

## Items that can be Accessed Directly from Keypad

### On Off Operation:

Pressing **ON** turns power on, pressing again turns power off. The unit will automatically shut off if there is no activity for 20 minutes. To defeat the automatic shut off, when turning the unit on press and hold the **BACKLIGHT** down and then press **ON**. When the unit is turned on, the entire display will be on momentarily, then the display will sequence to the home position, with the input type being displayed in the lower left display for a few seconds. To display the input type at any time, refer to "Items that can be accessed through the menu".

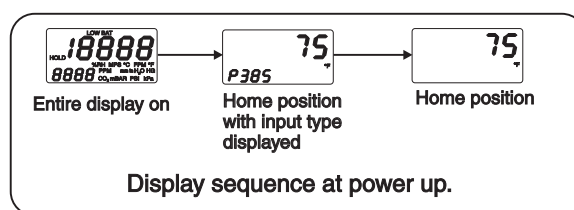

### Display Backlight:

Press **BACKLIGHT** to turn the backlight on, again to turn the backlight off. The Backlight will automatically turn off after 2 minutes to conserve battery power.

### Display Hold:

Pressing then releasing **HOLD** will freeze the display and turn on the "HOLD" annunciator.



### Input Type:

Press the **INPUT** key to display the input type. The lower left display will show the input type for a few seconds.

## Items that can be Accessed through the Menu

### How To Use The Menu

To access the menu, press **INDEX** to enter the menu mode. Continue pressing **INDEX** until the desired menu item is displayed. When the instrument is in the menu mode, the **HOLD** key will function as the "INCREMENT" key, and the **STORE** key will function as the "DECREMENT" key.

When the desired menu item is displayed, use the **HOLD** and **STORE** keys to modify the menu item to the desired value, then press **ENTER** to store the value in memory. If the enter key is not pressed, the original value will be retained in memory and not changed. To exit the menu mode, scroll to the home position. The instrument will automatically exit the menu mode if no key is pressed for one minute.

### Reading the Peak and Valley Values

The Peak (**PEA**) feature stores the highest reading the monitor has measured since the last reset or Power on. The Valley (**VAL**) features stores the lowest reading. At Power On, **PEA** and **VAL** are reset to the present reading.

To view the Peak or Valley values, press **INDEX** until the lower left display reads **PEA** or **VAL**. When **PEA** or **VAL** is displayed, pressing **ENTER** will reset the value to the present value.



#### Display Reading Peak Value



#### Display Reading Valley Value

### Setting the Input Type

Press **INDEX** until the lower left display reads **inP**. The present input type will be displayed in the upper display. To change the input type, scroll through the selections using the **HOLD** and **INPUT** keys. When the desired input type is displayed, press **ENTER** key to store.

#### Display the Input Type Mode

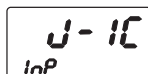

### Input Types:

- J-1C** Type "J" Thermocouple, Iron/Constantan (NIST)
- KA** Type "K" Thermocouple, Chromel/Alumel
- E-** Type "E" Thermocouple, Chromel/Constantan
- t-** Type "T" Thermocouple, Copper/Constantan
- n-** Type "N" Thermocouple, Nicrsil/Sisil
- r-13** Type "R" Thermocouple, PT 13% RH/Pt
- S-10** Type "S" Thermocouple, PT 10% RH/Pt
- b-** Type "b" Thermocouple, PT 6%/Rh/Pt 30%Rh
- n120** 120 ohm Nickel RTD
- P385** 100 ohm Platinum (DIN 0.00385  $\Omega/\Omega/^\circ\text{C}$ )
- IP38** 1000 ohm Platinum (DIN 0.00385  $\Omega/\Omega/^\circ\text{C}$ )
- Curr** DC Current Input 0 to 20 mA
- VoIt** DC Voltage Input 0.0 to 10.0 volts

### Setting the Units

If the input type is set for a thermocouple or RTD, the units may be set to  $^\circ\text{F}$  or  $^\circ\text{C}$ . If the input type is set for current or voltage, the units may be set for any of the following:

**nonE**, kPa, Pa, PSI, in Hg, mm Hg, in H<sub>2</sub>O, mm H<sub>2</sub>O, mBAR, BAR, PPM CO<sub>2</sub>, PPM CO, PPM, FPM, MPS, %RH,  $^\circ\text{C}$ , and  $^\circ\text{F}$

To change the input units, press **INDEX** until the lower display reads **UnIt**.

Scroll through the selections using the **HOLD** and **INPUT** keys. When the desired selection is displayed, press **ENTER** to store.

### Setting the Decimal Point

For Thermocouple and RTD inputs, the instrument may be set to no decimal point (0) or one decimal point (0.0). For current or voltage inputs, the decimal point may be set to:

0  
0.0  
0.00  
0.000  
.0000



#### Display in the Decimal Point mode.

To change the decimal point, press **INDEX** until the lower left display reads **dPt**.

Scroll through the selections using the **HOLD** and **INPUT** keys. When the desired selection is displayed, press **ENTER** to store.

### Setting or Viewing Scale Low and Scale High

For Thermocouple and RTD inputs, the Scale Low (**SCAL**) and Scale High (**SCAH**) values are viewable only, and represent the low end and high end of the range.

For Current and Voltage inputs the display may be

scaled to almost any desired value. For a current input, Scale Low would be the displayed value with an input of 0mA, and Scale High would be the displayed value with an input of 20mA. For a voltage input, Scale Low would be the displayed value with an input of 0V, and Scale High would be the displayed value with an input of 10V. Scale Low and Scale High may be set to any value from -19999 to +19999 as long as the following conditions are met:

1. Scale High must be higher than Scale Low.
2. Scale High must not be more than 32000 counts above Scale Low.

To adjust Scale High or Scale Low, press **INDEX** until the lower left display reads **SCAL** or **SCAH**, then use the **HOLD** and **INPUT** keys to set the desired value.

Press **ENTER** to store the value.



**Display Reading Scale Low**

For a current input, the actual input range is 0-20mA. For an input range of 4-20mA, the actual Scale Low setting must be offset by 20% to allow for the difference between 0mA (the actual low end of the analog scale) and 4mA (the desired low end of the analog scale).

Use the following formula to calculate the Scale Low setting:

$$SCAL = \text{Desired scale low end} - ((\text{Desired } SCAH - \text{Desired scale low end}) \div 4)$$

Example 1: The unit is wired to a differential pressure transmitter with a range of -0.25 to +0.25 inches of water column and an output of 4-20mA.

$$SCAL = -0.250 - ((+0.250 - -0.250) \div 4) = -0.250 - (0.500 \div 4) = -0.250 - 0.125 = -0.375$$

Example 2: The unit is wired to a Carbon Monoxide transmitter with a range of 0-1000 PPM and an output of 4-20mA.

$$SCAL = 0 - ((1000 - 0) \div 4) = 0 - (1000 \div 4) = 0 - 250 = -250$$

## Diagnostic Error Messages

Display	Meaning	Action Required
<b>UFL</b> or <b>OFL</b>	Underflow or Overflow: Process value has exceeded input range ends.	None, input signals may go beyond input range ends.
<b>bAd 1</b>	A/D converter failure.	Factory service required.
<b>bAd 2</b>	Non-volatile memory failure.	Factory service required.
<b>bAd 3</b>	Open RTD third wire.	Correct or replace sensor. To reset use the <b>INDEX</b> and <b>INPUT</b> keys.
<b>ArEr</b>	Ambient range of the instrument exceeded or RJC sensor broken.	Correct ambient temperature conditions. If error is still present, factory service is required.
<b>inEr</b>	The input has exceeded the range of the A/D converter.	Check input polarity, input signal value, and correct.

## Battery Installation

Remove two screws holding the bottom endcap labeled BATTERY in place and remove it. Connect the battery to the enclosed battery clip observing correct polarity. Insert the battery in the case. Be careful not to trap the wires between the case or foam pad, which retains the battery. This could make it difficult to install the battery or remove it later for replacement. Be sure the rubber gasket is properly seated in the gasket channel and replace the endcap. Note that the endcap will only fit one way because the holes are slightly off-center. Place the "Z" shaped wrist strap clip in one of the screw recesses and replace the screw. Do not overtighten. Attach the wrist strap to the clip.