

IsoVerter®II Model 4380

INSTALLATION INSTRUCTIONS

GETTING STARTED

Mount the socket and wire per instructions on below (Figure 2).

Refer to the exploded diagram in Figure 1. Carefully remove the four screws from the bottom of the plug end. Slide the cover off.

Program for desired input following instructions on Page 2.

Program for desired output following instructions on Page 3.

Refer to the exploded diagram in Figure 1. Carefully replace the cover and re-install the four screws to secure the cover to the base. Screws should be tightened to a snug fit.

Calibrate the unit using the procedure on page 4.



WARNING: Do not attempt to operate or calibrate this device with the cover removed. Potentially lethal voltage is present on some of the internal components.

Make sure that the cover is firmly in place before plugging into the socket.

WIRING

Wire the mounting socket as shown in the drawing shown in Figure 2.

For DIRECT ACTING inputs wire the positive lead to terminal five and the negative lead to terminal six (as shown).

For REVERSE ACTING inputs wire the positive input lead to terminal six and the negative lead to terminal five.

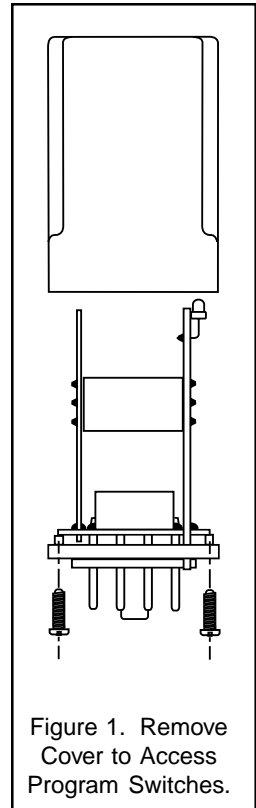

Figure 1. Remove Cover to Access Program Switches.

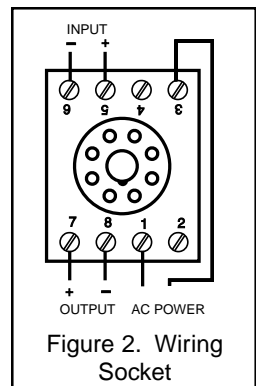

Figure 2. Wiring Socket

INPUT PROGRAMMING

The input selection and ranging is performed through two switch banks. Refer to the instructions below and the illustration in Figure 3 for details.

MODE SELECT SWITCH BANK

1. For CURRENT INPUT turn switch one ON.
For VOLTAGE INPUT turn switch one OFF.
2. For UNI-POLAR INPUT (low end of scale \geq zero) turn switch two ON and turn switch three OFF.
3. For BI-POLAR INPUT (low end of scale $<$ zero) turn switch two OFF and turn switch three ON .
4. For ZERO BASED INPUT (eg. 0 to 20 mA) turn switch four ON and switch five OFF.
5. For ZERO SUPPRESSION (eg. 4 to 20 mA) turn switch four OFF and switch five ON.
6. For DIRECT ACTING INPUT turn switch six OFF.
7. For REVERSE ACTING INPUT turn switch six ON and reverse input wiring.

RANGE SELECT SWITCH BANK

Turn ON the switch for the scale desired. All other switches should be OFF. If BI-POLAR INPUT is selected, the scale will be MINUS-SELECTION to PLUS-SELECTION (eg. -10 TO +10VDC).

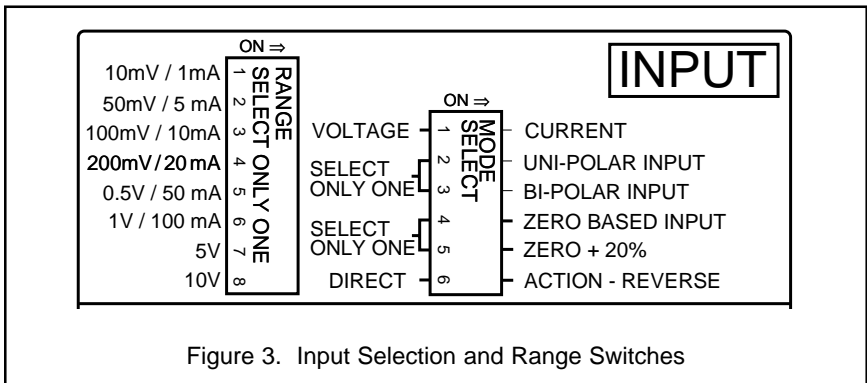

WARNING: Do not attempt to operate or calibrate this device with the cover removed. Potentially lethal voltage is present on some of the internal components. Make sure that the cover is firmly in place before plugging into the socket.

OUTPUT PROGRAMMING

The output selection and ranging is performed through two switch banks. Refer to the instructions below and the illustration in Figure 4 for details.

MODE SELECTION SWITCH BANK

1. For VOLTAGE OUTPUT turn switches one and two ON and switch three OFF.
2. For CURRENT OUTPUT turn switches one and two OFF and switch three ON.
3. For UNIPOLAR OUTPUT turn switch four ON and switch five OFF.
4. For BIPOLAR OUTPUT turn switch four OFF and switch five ON.
5. For ZERO BASED OUTPUT (eg. 0 TO 20 mA) turn switch six ON and switch seven OFF.
6. For ZERO SUPPRESSION (eg. 4 TO 20 mA) turn switch six OFF and switch seven ON. If BIPOLAR or REVERSE ACTION is selected, do not use the ZERO SUPPRESSION switch. Use the ZERO adjustment to suppress the output.
7. Switch eight is always OFF. (It is not connected to any circuitry. If switch eight is turned ON there is no effect on the operation of the device.)

RANGE SELECTION SWITCH BANK

Turn ON the switch for the scale desired. All other switches should be OFF. If BIPOLAR OUTPUT is selected, the scale will be from MINUS-SELECTION to PLUS-SELECTION (eg. -10 TO +10 VDC)

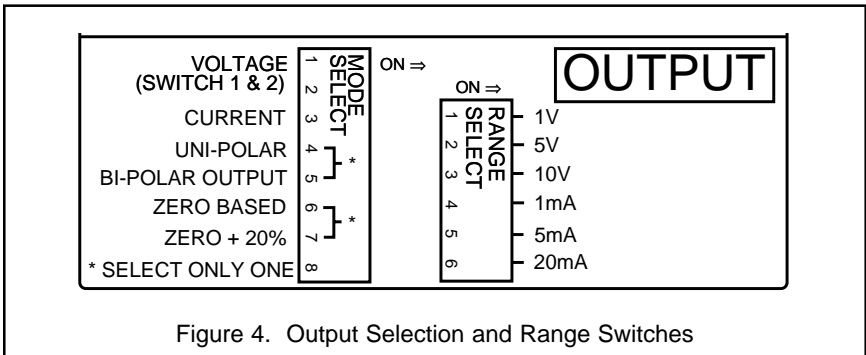

WARNING: Do not attempt to operate or calibrate this device with the cover removed. Potentially lethal voltage is present on some of the internal components. Make sure that the cover is firmly in place before plugging into the socket.



WARNING: Do not attempt to operate or calibrate this device with the cover removed. Potentially lethal voltage is present on some of the internal components. Make sure that the cover is firmly in place before plugging into the socket.

CALIBRATION

1. Apply the appropriate input for the low end of the scale.
2. Adjust the ZERO screw for the desired low end output (4mA for example).
3. Apply the appropriate input for the high end of the scale.
4. Adjust the SPAN screw for the desired high end output (20mA for example).
5. Repeat as necessary.



Figure 5. Calibration Adjustment Location

SPECIFICATIONS

Power Supply: 85 to 265 VDC / VAC 50 to 400 Hz.

Isolation: 1500 VAC

Ambient Temperature Range (operating): 0° to 50° C (32° to 131° F)

Linearity: 0.1%

Drift: $\pm 0.02\%$ per °C typical, $\pm 0.05\%$ maximum.

Maximum current output load: 600 ohms.

Maximum voltage output load: 20mA (500 ohms).

Input impedance - current: 10 ohms.

Input impedance - voltage: 1 Megohm.

LOVE CONTROLS DIVISION

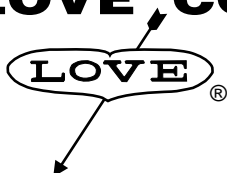

Dwyer Instruments, Incorporated

PO Box 338 ○ Michigan City, IN 46361-0338

(800) 828-4588 ○ (219) 879-8000 ○ FAX (219) 872-9057

www.love-controls.com