

Iso Verter®II

Model SC4380 and SCL4380

INSTALLATION INSTRUCTIONS

Getting Started

- 1.) Using a small screwdriver, ball point pen, etc. set the four switches on the side of the unit (see Input Programming and Output Programming on page 2).
 - 2.) Mount unit into panel. (see Mounting on page 3).
 - 3.) Connect unit to input signal, output signal, and power wiring (see Wiring on page 4).
 - 4.) Check calibration (See Calibration on page 4).
- Specifications are on page 4.

Dimensions

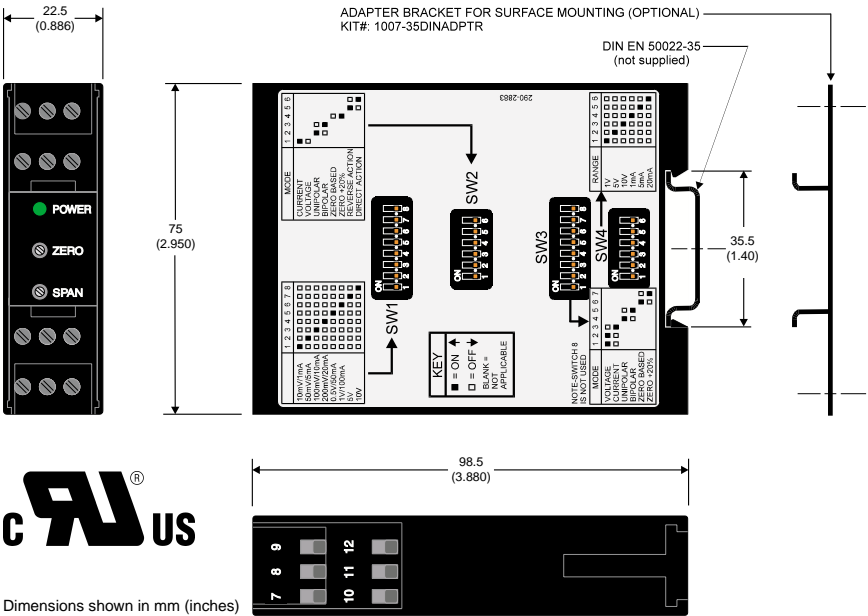

Dimensions shown in mm (inches)



LOVE CONTROLS

a Division of Dwyer Instruments, Incorporated
 PO Box 338 ○ Michigan City, IN 46361-0338
 (800) 828-4588 ○ (219) 879-8000 ○ FAX (219) 872-9057
www.love-controls.com

Input Programming

RANGE SELECTION SWITCH BANK (SW-1)

Turn ON the switch for the scale desired. All other switches should be OFF. If BI-POLAR INPUT is selected, the scale will be MINUS-SELECTION to PLUS-SELECTION (eg. -10 TO +10VDC).

MODE SELECTION SWITCH BANK (SW-2)

1. For CURRENT INPUT turn switch one ON. For VOLTAGE INPUT turn switch one OFF.
2. For UNI-POLAR INPUT (low end of scale \geq zero) turn switch two ON and turn switch three OFF.
3. For BI-POLAR INPUT (low end of scale $<$ zero) turn switch two OFF and turn switch three ON .
4. For ZERO BASED INPUT (eg. 0 TO 20 mA) turn switch four OFF.
5. For ZERO SUPPRESSION (eg. 4 TO 20 mA) turn switch four ON.
6. For DIRECT ACTING INPUT turn switch five OFF and switch six ON. For REVERSE ACTING INPUT turn switch five ON and switch six OFF.

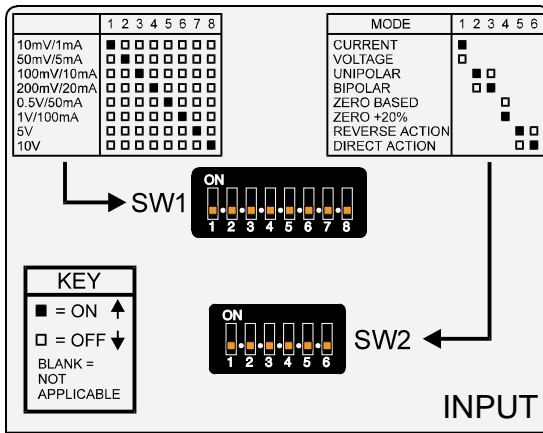

Output Programming

MODE SELECTION SWITCH BANK (SW-3)

1. For VOLTAGE OUTPUT turn switches one and two ON and switch three OFF.
2. For CURRENT OUTPUT turn switches one and two OFF and switch three ON.
3. For UNIPOLAR OUTPUT turn switch four ON and switch five OFF.
4. For BIPOLAR OUTPUT turn switch four OFF and switch five ON.

5. For ZERO BASED OUTPUT (eg. 0 TO 20 mA) turn switch six ON and switch seven OFF.
6. For ZERO SUPPRESSION (eg. 4 TO 20 mA) turn switch six OFF and switch seven ON. If BIPOLAR is selected, do not use the ZERO SUPPRESSION switch. Use the ZERO adjustment to suppress the output.
7. Switch eight is always OFF. (It is not connected to any circuitry. If switch eight is turned ON there is no effect on the operation of the device.)

RANGE SELECTION SWITCH BANK (SW-4)

Turn ON the switch for the scale desired. All other switches should be OFF. If BIPOLAR OUTPUT is selected, the scale will be from MINUS-SELECTION to PLUS-SELECTION (eg. -10 TO +10 VDC)

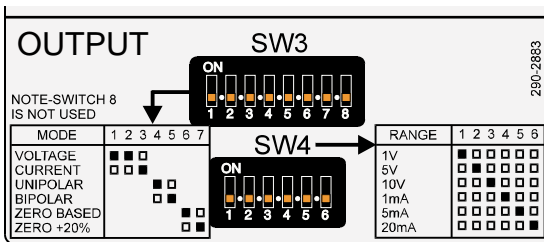

WARNING: Do not attempt to operate this device with the cover removed. Potentially lethal voltage is present on some of the internal components. Do not open the unit. There are no internal adjustments or user serviceable parts in the unit.

Mounting

Mount the unit in a panel that will not be subject to excessive temperature, shock, or vibration. All models are designed for mounting on an industry standard 35 mm DIN rail. An optional surface mounting kit is available from the factory (P/N 35DINADPTR).

To install hold the SC4380 so that the front is higher than the rear. Place the upper slot on the rear of the SC4380 on the top edge of the DIN rail. Slowly rotate the front down until the bottom spring clip snaps over the bottom edge of the DIN rail.

To remove from the DIN rail, place a small slotted screwdriver in the slot in the spring clip under the housing. Pry the slot downward to release the SCU from the bottom of the rail.



Wiring

The wiring terminals for the SC4380 and SCL4380 are compression type. To open the wiring terminal, turn the screw for that terminal counterclockwise. Slide the wire into the terminal space. While holding the wire in place, turn the screw clockwise to tighten. Do not overtighten. The wire should be held snugly in place.

Power for SC4380 is 85 to 265 Vdc/Vac 50 to 400 Hz.
Power for SCL4380 is 12 to 24 Vdc/Vac 50 to 400 Hz.

Wire the input, output, and power as shown on the wiring label. **Do not run Class 2 signal wires adjacent to or in the same conduit as power wires.**

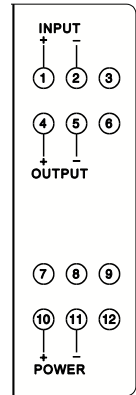

Calibration

1. Apply the appropriate input for the low end of the scale.
2. Adjust the ZERO screw for the appropriate low end output.
3. Apply the appropriate input for the high end of the scale.
4. Adjust the SPAN screw for the appropriate high end output.
5. Repeat as necessary.

Specifications

Power Supply: SC4380: 85 to 265 Vac/ Vac 50 to 400 Hz.

SCL4380: 12 to 24 Vdc/Vac 50 to 400 Hz. $\pm 20\%$

Isolation: 1500 VAC

Ambient Temperature Range:

Operating: 0° to 55° C (32° to 131° F)

Storage: -40° to +80° C (-40° to +176° F)

Humidity Conditions: 0 to 90% up to 40 °C non-condensing, 10 to 50% at 55 °C non-condensing.

Linearity: 0.1%

Drift: $\pm 0.02\%$ per °C typical, $\pm 0.05\%$ maximum.

Maximum current output load: 600 ohms.

Maximum voltage output load: 20mA (500 ohms).

Input impedance - current: 10 ohms.

Input impedance - voltage: 1 Megohm.

Agency Approvals: UL Recognized, US and Canada, E83725.