



## Series 631 Differential Pressure Transmitter

### Specifications - Installation and Operating Instructions



Series 631B

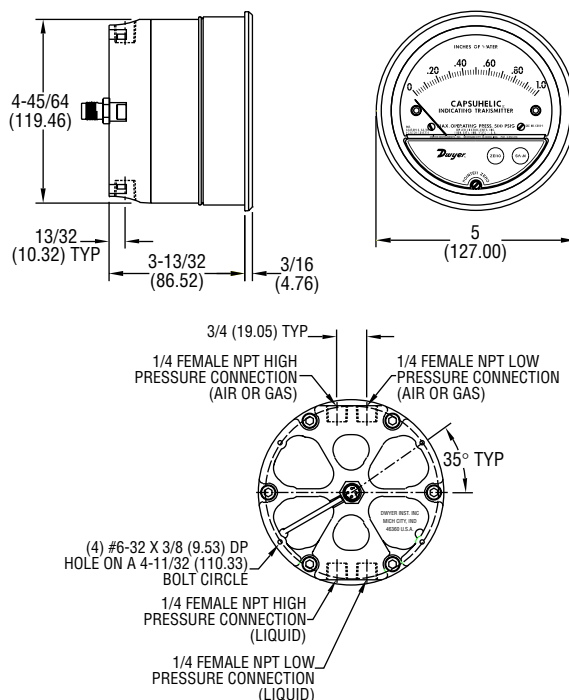

The Dwyer **Series 631 Differential Pressure Transmitter** monitors differential pressure of air and compatible gases and liquids. The design employs converting pressure changes into a standard 4-20 mA output signal for two wire circuits. Digital push-button, zero and span adjustments are easily accessed on the front cover. The Series 631 Differential Pressure Transmitter is designed to meet NEMA-4X (IP66) construction.

#### INSTALLATION

**1. Location:** Select a location where the temperature of the unit will be between 20 and 120°F. Distance from the receiver is limited only by total loop resistance (see electrical connections). The tubing feeding pressure to the instrument can be practically any length required, but long lengths will increase the response time slightly. Mount the instrument in a location that will not be subject to excessive temperature, shock or vibration.

**2. Position:** A vertical position is recommended (pressure connections pointing vertically) since that is how all standard models were originally spanned and zeroed at the factory.

**3. Pressure Connection:** Dual 1/4" female NPT pressure connections are provided. Use Teflon® thread tape or other suitable pipe joint compound when making connection to the pressure source. Avoid excess sealant which could block the pressure passage. When monitoring liquid pressures, air trapped in the lines can cause incorrect readings. Bleed fittings or similar mechanisms should be used to bleed off any trapped air.

#### SPECIFICATIONS

**Service:** Compatible gases & liquids.

**Wetted Materials:** Brass, silicone, 300 SS.

**Accuracy:** Transmitter Output:  $\pm 2\%$  F.S. (includes linearity, hysteresis and repeatability). Gage:  $\pm 3\%$  of full scale at 70°F (21.1°C).

**Stability:**  $\pm 1\%$  F.S./yr.

**Temperature Limits:** 20 to 120°F (-6.67 to 48.9°C).

**Pressure Limits:** -20" Hg to 500 psig. (-0.677 bar to 34.4 bar).

**Thermal Effect:** Greater than 1" ranges:  $\pm 0.025\%/^{\circ}\text{F}$  ( $\pm 0.045\%/^{\circ}\text{C}$ ); 1" range:  $\pm 0.045\%/^{\circ}\text{F}$  ( $\pm 0.081\%/^{\circ}\text{C}$ ); 0.5" range:  $\pm 0.09\%/^{\circ}\text{F}$  ( $\pm 0.162\%/^{\circ}\text{C}$ ).

**Power Requirements:** 10-35 VDC.

**Output Signal:** 4 to 20 mA.

**Response Time:** 50 msec.

**Loop Resistance:** 0-1250 ohms maximum.

**Electrical Connections:** M-12 circular 4 pin connector.

**Process Connections:** 1/4" female NPT high and low pressure taps, duplicated - one pair top for air and gas, and one pair bottom for liquids.

**Enclosure Rating:** Designed to meet NEMA 4X (IP66).

**Mounting Orientation:** Diaphragm in vertical position. Consult factory for other position orientations.

**ELECTRICAL CONNECTIONS**

**CAUTION:** Do not exceed specified supply voltage ratings. Permanent damage not covered by warranty will result. This unit is not designed for 120 or 240 volt AC line operation.

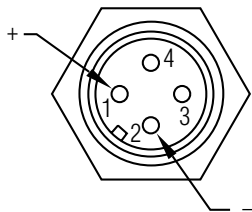

Fig. A

**Wire Length** - The Maximum length of wire connecting transmitter and receiver is a function of wire size and receiver resistance. Wiring should not contribute to more than 10% of receiver resistance to total loop resistance. For extremely long runs (over 1000 ft.), choose receivers with higher resistance to minimize size and cost of connecting leads. When the wiring length is under 100 feet, lead wire as small as 22 AWG can be used.

**Current (4-20 mA) Output Operation** - An external power supply delivering 10-35 VDC with minimum current capability of 40 mA DC (per transmitter) must be used to power the control loop. See Figure B for connection of the power supply, transmitter, and receiver. The range of the appropriate receiver load resistance ( $R_L$ ) for the DC power supply voltage available is expressed by the formula:

$$R_L \text{ Max} = \frac{V_{ps} - 10}{20 \text{ mA DC}}$$

Shielded two wire cable is recommended for control loop wiring. If grounding is required use negative side of control loop after receiver, see Figure B.

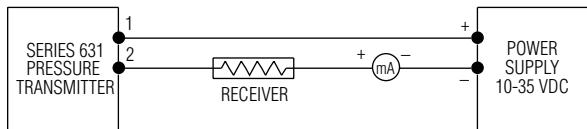
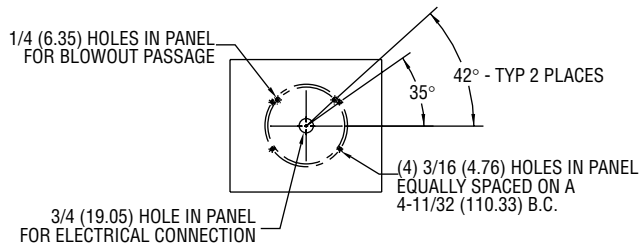
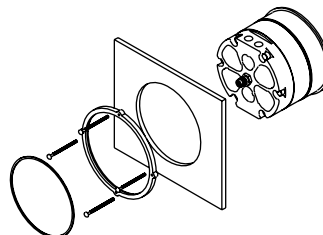
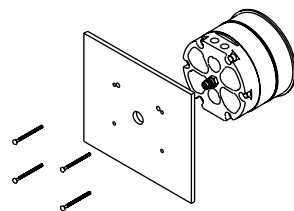

Fig. B

**MULTIPLE RECEIVER INSTALLATION**

An advantage of the standard 4-20 mA DC output signal provided by the Series 631 Differential Transmitter is that any number or receivers can be connected in series in the current loop. Thus, an A-701 digital readout, an analog panel meter, a chart recorder, process controlling equipment, or any combination of these devices can be operated simultaneously. It is necessary only that each be equipped with a standard 4-20 mA input and proper polarity of the input connections be observed when inserting the device into the current loop. If any of the receiving devices displays a negative or downscale reading this indicates that the signal input leads are reversed.

**MOUNTING OPTIONS**



SURFACE MOUNT HOLE PATTERN

**MAINTENANCE**

Upon final installation of the Series 631 Differential Pressure Transmitter and the companion receiver, no routine maintenance is required. A periodic check of the system calibration is recommended. The Series 631 Differential Pressure Transmitter is not field serviceable and should be returned if repair is needed (field repair should not be attempted and may void warranty). Be sure to include a brief description of the problem plus any relevant application notes. Contact customer service to receive a return goods authorization number before shipping.