

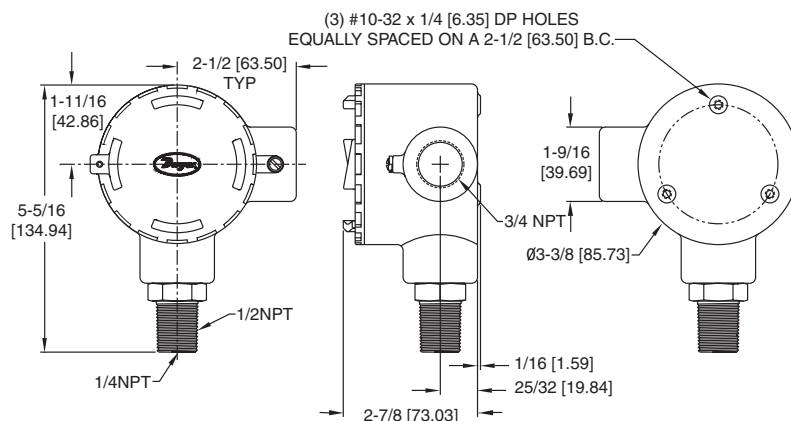

## Series 634ES Pressure Transmitter

### Specifications - Installation and Operating Instructions

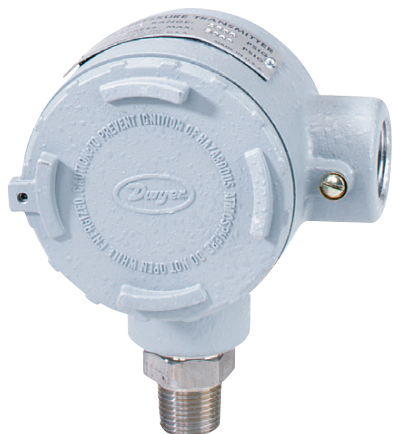

The **Series 634ES Pressure Transmitter** senses a single air, compatible gas or liquid pressure and converts it into a standard 4-20 mA output signal. Ranges are available from 0-10 through 0-6000 psi. All models are field adjustable so any range within these limits can be achieved by recalibration using the easily accessible span and zero potentiometers.

Positive pressure can be measured within an accuracy of  $\pm 0.5\%$  of span. The Series 634ES uses an isolated piezoresistive pressure sensor to produce a resistance change across a wheatstone bridge. The signal is conditioned and converted into a 4-20 mA output signal.

For applications requiring direct pressure or percent of full span readings, the optional A-701 digital readout makes an ideal companion device, providing a bright .6" high, 3-1/2" digit LED and supplying power to the Series 634ES Transmitter.

Model Number	Series 634ES Models and Ranges in PSI (bar)			
	As Stocked	Min. Range	Max. Range	Max Pressure
634ES-0	10 (.69)	10 (.69)	20 (1.38)	30 (2.07)
634ES-1	30 (2.07)	20 (1.38)	40 (2.76)	60 (4.14)
634ES-2	50 (3.45)	40 (2.76)	60 (4.14)	100 (6.9)
634ES-3	100 (6.9)	60 (4.14)	120 (8.3)	200 (13.8)
634ES-4	200 (13.8)	100 (6.9)	250 (17.2)	400 (27.6)
634ES-5	300 (20.7)	250 (17.2)	350 (24.1)	500 (34.5)
634ES-6	500 (34.5)	350 (24.1)	600 (41.4)	1000 (69)
634ES-7	1000 (69)	600 (41.4)	1250 (86)	2000 (138)
634ES-8	2000 (138)	1250 (86)	2500 (172)	4000 (276)
634ES-9	4000 (276)	2500 (172)	6000 (414)	7500 (517)

#### PHYSICAL DATA

##### GENERAL

**Maximum Pressure:** See chart on this page.

**Wetted Parts:** 316, 316L Stainless Steel.

**Housing:** Designed to meet NEMA-4X.

##### ELECTRICAL

**Power Supply:** 12.3-35 VDC-2 wire.

**Output Signal:** 4-20 mA DC (limited at 38 mA DC).

**Loop Resistance:** 0 - 1100 ohms from 12.3 to 35 VDC.

$$R_{L \max} = \frac{V_{ps} - 12.3V}{20 \text{ mA}}$$

**Current Consumption:** DC: 38 mA max.

##### MATERIALS

**Housing:** Cast aluminum; textured gray polyurethane finish.

**Pressure Connection:** Stainless Steel.

##### MECHANICAL

**Weight:** 1 lb., 12 oz. (.8 kg).

**Span and Zero Adjustments:** Protected potentiometers, located in auxiliary housing.

**Pressure Connection:** 1/4" female NPT x 1/2" male NPT.

##### PERFORMANCE AT 70°F (21.1°C)

**Zero Output:** 4 mA DC.

**Full Span:** 16 mA DC.

**Accuracy:**  $\pm 0.5\%$  of span.

**Warm-up Time:** 10 minutes.

##### STABILITY/ENVIRONMENTAL

**Operating Temperature:** 20 to 120°F (- 6.7 to 48.9°C).

**Thermal Errors:**  $\pm 0.02\%/F$  typical.

**Stability:** 1% F.S./yr.

##### STANDARD ACCESSORIES

(3) "Z" mounting brackets.

(3) 10-32 x 4" RH machine screws.

## Series 634ES Pressure Transmitter

### Specifications - Installation and Operating Instructions

#### INSTALLATION

**LOCATION:** Select a location where temperature of the unit will be between 20°F and 120°F. Distance from the receiver is limited only by total loop resistance. See "Electrical Connections." The tube feeding the pressure to the instrument can be run practically any length required, but long lengths will slightly increase response time. Avoid surfaces with excessive vibration.

**POSITION:** A vertical position is recommended, as all stocked models are spanned and zeroed at the factory in this position. They can be used at other angles, but final spanning and zeroing must be done while transmitter is in the alternative position.

**PRESSURE CONNECTIONS:** A single pressure connection is provided at the bottom of the transmitter housing. It has 1/4" female NPT and 1/2" male NPT threads. Attach positive pressure to this port.

**MOUNTING:** The Series 634ES Transmitter can be mounted three ways:

- (A) Supported directly by pipe providing pressure.
- (B) Attached to a mounting surface with 10-32 x 1/4" machine screws (included). The machine screws are installed through the mounting surface into tapped holes on back of unit.
- (C) Mounted with "Z" brackets (included). Attach "Z" brackets to tapped holes on back of unit and fasten to front of mounting surface.

#### ELECTRICAL CONNECTIONS

**CAUTION:** DO NOT EXCEED SPECIFIED SUPPLY VOLTAGE RATINGS. PERMANENT DAMAGE NOT COVERED BY WARRANTY WILL RESULT. THIS UNIT IS NOT DESIGNED FOR AC VOLTAGE OPERATION.

Electrical connections to the Series 634ES Transmitter are made inside the enclosure. Remove the cover, feed stripped and tinned leads through the conduit opening and connect to terminal block screws marked + and -. See Figure A for locations of terminal block, span and zero adjust potentiometers. See Figure B (Pg. 3) for schematic diagram.

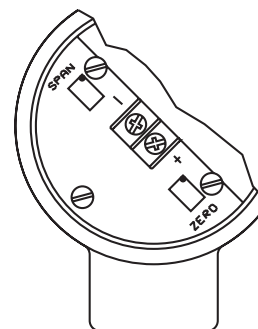

FIG. A

An external power supply delivering 12.3 to 35 VDC with minimum current capability of 40 mA must be used to power the control loop in which the Series 634ES Transmitter is connected. See Figure B for connection of the power supply, transmitter and receiver.

The range of appropriate receiver load resistance ( $R_L$ ) for the power supply voltage available is given by the formula and graph in Figure C on Pg. 3.

Shielded 2-wire cable is recommended for control loop wiring, and the cable shielding may be grounded if desired. Note also that the receiver may be connected in either the negative or positive side of the loop, whichever is most convenient.

Should polarity of the transmitter or receiver inadvertently become reversed, the loop will not function properly, but no damage will be done to the transmitter.

## Series 634ES Pressure Transmitter

### Specifications - Installation and Operating Instructions

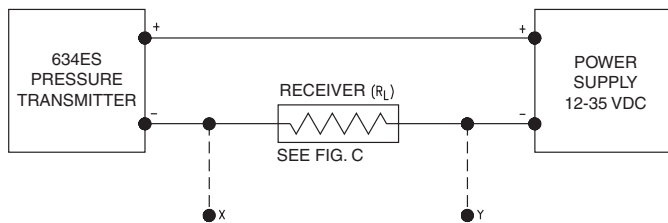

FIG. B

Series 634ES Transmitters can be used with receivers requiring 1-5 volt input rather than 4-20 mA. If the receiver requires a 1-5 volt input, insert a 250 ohm, 2 watt resistor in series with the current loop but in parallel with the receiver input. Referring to Figure B,  $R_L$  becomes the 250 ohm resistor and points X and Y are connected to the receiver input, point X being positive (+) and point Y negative (-) or ground. The resistor should be connected at the panel end of the transmitter current loop close to the receiver input to take advantage of the immunity of the current loop to electrical noise pickup. Most electronic component distributors stock a 249  $\Omega$ , 2 watt,  $\pm 1\%$  tolerance metal film resistor which is adequate for this application.

**WIRE LENGTH** - The maximum length of wire connecting transmitter and receiver is a function of wire size and receiver resistance. Wiring should not contribute more than 10% of receiver resistance to total loop resistance. For extremely long runs (over 1000 feet) choose receivers with higher resistances to minimize size and costs of connecting leads. When wiring length is under 100 feet, lead wire as small as 22 AWG can be used.

**PRESSURE RANGING** - Each Series 634ES Transmitter is factory-calibrated to the range given in the model number chart. However, special calibration is also available. If this is the case, the transmitter will be so marked. For purposes of clarification in these instructions, range is defined as that pressure which, applied to the transmitter, produces 20 mA of current in the loop. Zero pressure is always assumed to be 4 mA. If a transmitter pressure range other than that supplied is required, follow the re-ranging procedure described on Pg. 4.

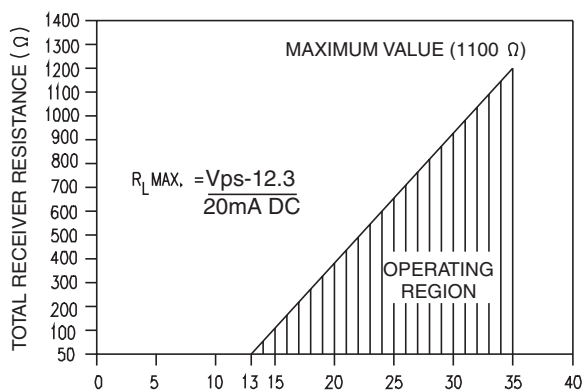

FIG. C

## Series 634ES Pressure Transmitter

### Specifications - Installation and Operating Instructions

#### PRESSURE RE-RANGING PROCEDURE

1. With the transmitter correctly connected to the companion receiver, an accurate milliammeter with a full scale reading of approximately 30 mA should be inserted in series with the current loop. A controllable pressure source capable of achieving the desired range should be connected to the pressure port of the transmitter and teed into an accurate reference pressure gauge or manometer. The instrument must be ranged in the same position in which it will be used. Vertical mounting is recommended.
2. Apply electrical power to the system and allow it to stabilize for 10 minutes.
3. With no pressure applied to the transmitter, adjust "zero" control so that loop current is 4 mA.
4. Apply full range pressure and adjust loop current to 20 mA using "span" control.
5. Relieve pressure and allow transmitter to stabilize for two minutes.
6. Zero and span adjustments may be interactive, so repeat steps 3 through 5 until zero and full range pressures consistently produce loop currents of 4 and 20 mA respectively.
7. Remove the milliammeter from the current loop and proceed with final installation of the transmitter and receiver.

#### MULTIPLE RECEIVER INSTALLATION

An advantage of the standard 4-20 mA output signal provided by the Series 634ES Pressure Transmitter is that any number of receivers can be connected in series in the current loop. Thus, an A-701 Digital Readout Accessory, an analog panel meter, a chart recorder, process controlling equipment, or any combination of these devices can be operated simultaneously. It is only necessary that these devices all be equipped with a standard 4-20 mA input and that proper polarity of the input connections be observed when inserting the device in the current loop. If any of the receiving devices displays a negative or down-scale reading, this indicates that the signal input leads are reversed.

#### MAINTENANCE

Upon final installation of the Series 634ES Transmitter and the companion receiver, including the A-701 Digital Readout, no routine maintenance is required. A periodic check of system calibration is recommended. The Series 634ES Pressure Transmitter is not field serviceable and should be returned, freight prepaid, to the factory if repair is required. The A-701 Digital Readout should be returned to the manufacturer if service is needed. Refer to the A-701 instruction sheet.