

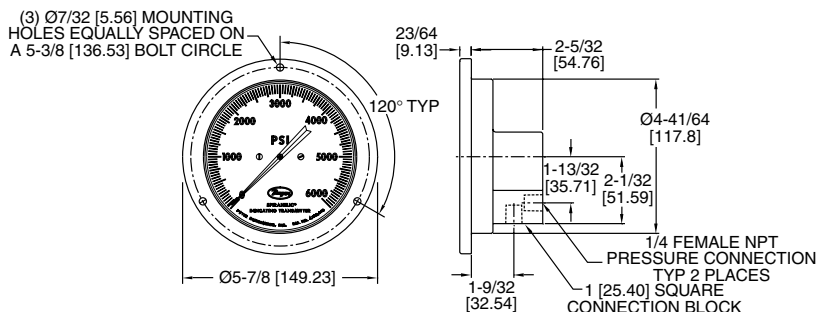

## Series 7000 Spirahelic® Pressure Indicating Transmitter

### Specifications - Installation and Operating Instructions



The Dwyer Series 7000 Spirahelic® Pressure Indicating Transmitter provides local indication on a large, easy-to-read analog scale while also converting that pressure into a standard two wire 4-20 mA output signal. Positive pressure of compatible gases or liquids is measured with 1/2% of full scale accuracy. The gage employs a triple helix Bourdon tube movement with direct drive design to reduce friction and mass for exceptional responsiveness, repeatability and accuracy. Because there are no gears, springs, linkages or other complicated mechanisms, wear is practically eliminated. The electrical output signal is produced by a piezoresistive pressure sensor mounted on the pressure block. The pressure block also includes an integral filter plug to protect the gage interior from dirt and other particulates. Safety is assured with a solid front case design and a rear blowout hole.

#### INSTALLATION

1. Select a location free from excessive vibration where the temperature limits of 20° to 120°F (-6.7° to 49°C) will not be exceeded. The mounting surface should be vertical to match the position in which all standard gages are calibrated. Avoid locations in direct sunlight which may cause accelerated discoloration of the clear acrylic lens or where exposure to oil mist or other airborne vapors could likewise result in lens damage. Make sure that the case relief area on the rear is not obstructed. This hole is designed to direct pressure rearward in the event of failure or the Bourdon tube element. See complete safety recommendations in this bulletin.

2. Cut a 4.94" (125 mm) mounting hole and drill (3) 7/32" (5.56 mm) bolt holes on a 5.38" (137 mm) bolt circle as shown in drawing above. Attach gage to panel with (3) 3/16" bolts of appropriate length.

#### SPECIFICATIONS

##### GAGE SPECIFICATIONS

**Service:** Compatible gases & liquids

**Wetted Materials:** Inconel® X-750 Bourdon Tube, Type 316L SS connection.

**Housing:** Black polycarbonate case and clear acrylic cover.

**Accuracy:** Grade 2A (0.5% F.S.).

**Stability:** ± 1% F.S./yr.

**Pressure Limit:** 150% of full scale. Gage will maintain its specifications for overpressures up to 150% maximum range. Normal operation should be between 25% and 75% of full scale.

**Temperature Limits:** 20 to 120°F (-6.67 to 48.9°C).

**Size:** 4 -1/2" dial face (114.3 mm), Design conforms to ASME B40.1.

**Process Connections:** Two 1/4" female NPT field selectable back or bottom connection.

**Weight:** 17.1 oz. (581 g).

##### TRANSMITTER SPECIFICATIONS

**Accuracy:** 0.5% F.S.

**Temperature Limits:** 20 to 120°F (-6.67 to 48.9°C).

**Thermal Effect:** ±0.025% F.S. /°F (0.045% F.S./°C).

**Power Requirements:** 10-35 VDC (2 wire).

**Output Signal:** 4-20 mA DC.

**Zero & Span Adjustments:** Externally accessible potentiometers.

**Loop Resistance:** DC, 0-1250 ohms.

**Current Consumption:** DC, 38 mA max.

**Electrical Connections:** Screw Terminals.

**Mounting Orientation:** Vertical.

**Agency Approvals:** CE.

3. Two 1/4" female NPT pressure connections are furnished to allow a choice of vertical or horizontal piping. The unused port should be plugged. Use a minimal amount of thread sealant. Too much could block the internal pressure passage.

**CAUTION:** When installing fittings or pipe always use a second wrench on the 1" pressure block DO NOT allow torque to be transmitted from block to the gage case.

**PNEUMATIC CALIBRATION TESTER**

Use a dead weight tester or certified test gage with .125% or better accuracy. The test gage range should be comparable to the range of the Spirahelic® Pressure Indicating Transmitter being checked. Connect the lines from the two instruments to a tee and the third line from the tee to a controllable source of pressure. Apply pressure slowly so pressure equalizes throughout the system. Compare readings, if gage being tested is found to need calibration, return it, freight prepaid to the factory.

**ELECTRICAL CONNECTIONS**

**CAUTION:** Do not exceed specified supply voltage ratings. Permanent damage not covered by warranty will result. This unit is not designed for 120 or 240 volt AC line operation.

Electrical connections to the Series 7000 Spirahelic® Pressure Indicating Transmitter are made at the rear of the pressure gage. Feed stripped and tinned leads to the terminal block screws shown below, refer to Figure A for locations of the terminal block, span and zero adjustments.

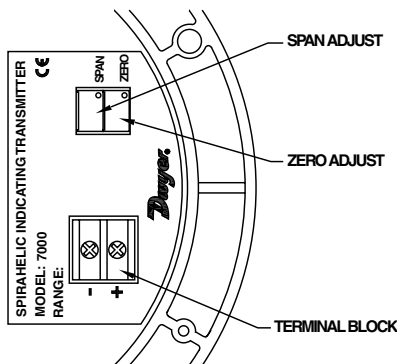

Fig. A

**2-Wire Operation** - A external power supply delivering 10-35 VDC with minimum current capability of 40 mA DC (per transmitter), must be used to power the control loop. See Figure B for connection of the power supply, transmitter, and receiver. The range of the appropriate receiver load resistance (R<sub>L</sub>) for the DC power supply voltage available is expressed by the formula and graph in Figure C. Shielded two wire cable is recommended for control loop wiring. If grounding is required use negative side of control loop after receiver see Figure B.

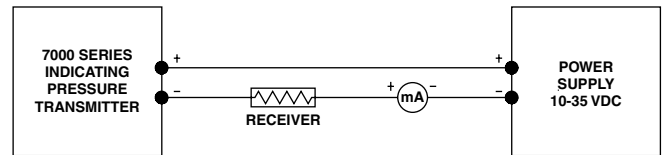

Fig. B

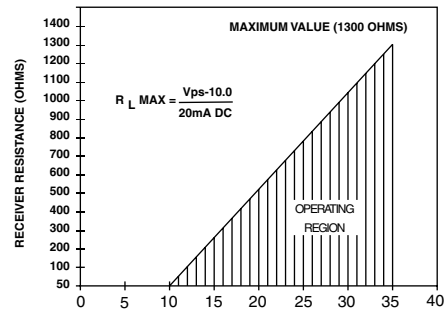

Fig. C

**PRESSURE RANGING**

Each standard Series 7000 Spirahelic® Pressure Indicating Transmitter is factory calibrated to produce a 4 mA output signal at zero pressure and a 20 mA signal at full scale. Use the following procedure to check or adjust the output signal calibration.

1. With the unit connected to its companion receiver and power supply, an accurate milliammeter should be inserted in series with the current loop. A controllable pressure source capable of achieving the necessary full scale pressure should be connected to the pressure port of the transmitter and teed to an accurate pressure gage or manometer. The instrument should be calibrated in the same position in which it will be used. Vertical mounting is recommended.

2. Apply electrical power to the system and allow it to stabilize for 10 minutes.
3. With no pressure applied to the transmitter, adjust "Zero" control so that loop current is 4 mA.
4. Apply full scale pressure and adjust "Span" control so that loop current is 20 mA.
5. Relieve pressure and allow transmitter to stabilize to 2 minutes.
6. Zero and Span controls are slightly interactive so repeat steps 3 through 5 until zero and full scale pressures consistently produce loop currents of 4 and 20 mA respectively.
7. Remove milliammeter from the current loop and proceed with final installation of the transmitter and receiver.

#### **WIRE LENGTH**

The maximum length of wire connecting transmitter and receiver is a function of wire size and receiver resistance. Wiring should not contribute to more than 10% of receiver resistance to total loop resistance. For extremely long runs (over 1000 feet), choose receivers with higher resistance's to minimize size and cost of connecting leads. When the wiring length is under 100 feet, lead wire as small as 22 awg can be used.

#### **MULTIPLE RECEIVER INSTALLATION**

An advantage of the standard 4-20 mA DC output signal provided by the 7000 Spirahelic® Pressure Indicating Transmitter is that any number or receivers can be connected in series in the current loop. Thus, an A-701 digital read-out, an analog panel meter, a chart recorder, process controlling equipment, or any combination of these devices can be operated simultaneously. It is necessary only that each be equipped with a standard 4-20 mA input and proper polarity of the input connections be observed when inserting the device into the current loop. If any of the receiving devices displays a negative or downscale reading this indicates that the signal input leads are reversed.

#### **MAINTENANCE**

Upon final installation of the Series 7000 Spirahelic® Pressure Indicating Transmitter and the companion receiver, no routine maintenance is required. A periodic check of the system calibration is recommended. The Series 7000 Spirahelic® Pressure Indicating Transmitter is not field serviceable and should be returned freight prepaid, to the factory (listed below) if repair is required (field repair should not be attempted and may void warranty).

Dwyer Instruments, Inc.  
Attn: Repair Department  
102 Highway 212  
Michigan City, IN 46360

The following material is excerpted from a standard titled **Gauges-Pressure Indicating Dial Type-Elastic Element** (ANSI/ASME B40.1-1985) as published by The American Society of Mechanical Engineers, 345 East 47th St. New York, NY 10017. This information is furnished to assist the user of Dwyer Spirahelic® gages in properly evaluating their suitability for the intended application and conditions.

## 4 SAFETY

### 4.1 Scope

This Section of the Standard presents certain information to guide users, suppliers, and manufacturers toward minimizing the hazards that could result from misuse or misapplication of pressure gauges with elastic elements. The user should become familiar with all sections of this Standard, as all aspects of safety cannot be covered in this Section. Consult the manufacturer or supplier for advice whenever there is uncertainty about the safe application of a pressure gauge.

### 4.2 General Discussion

**4.2.1** Adequate safety results from intelligent planning and careful selection and installation of gauges into a pressure system. The user should inform the supplier of all conditions pertinent to the application and environment so that the supplier can recommend the most suitable gauge for the application.

**4.2.2** The history of safety with respect to use of pressure gauges has been excellent. Injury to personnel and damage to property have been minimal. In most instances, the cause of failure has been misuse or misapplication.

**4.2.3** The pressure sensing element in most gauges is subjected to high internal stresses, and applications exist where the possibility of catastrophic failure is present. Pressure regulators, chemical (diaphragm) seals, pulsation dampers or snubbers, syphons, and other similar items, are available for the use in these potentially hazardous systems. The hazard potential increases at higher operating pressure.

**4.2.4** The following systems are considered potentially hazardous and must be carefully evaluated:

- (a) compressed gas systems
- (b) oxygen systems
- (c) systems containing hydrogen or free hydrogen atoms
- (d) corrosive fluid systems (gas and liquid)
- (e) pressure systems containing any explosive or flammable mixture or medium
- (f) steam systems
- (g) nonsteady pressure systems
- (h) systems where high overpressure could be accidentally applied
- (i) systems wherein interchangeability of gauges could result in hazardous internal contamination or where lower pressure gauges could be installed in higher pressure systems
- (j) systems containing radioactive or toxic fluids (liquids or gases)
- (k) systems installed in a hazardous environment

**4.2.5** When gauges are to be used in contact with media having known or uncertain corrosive effects or known to be radioactive, random or unique destructive phenomena can occur. In such cases the user should always furnish the supplier or manufacturer with information relative to the application and solicit his advice prior to installation of the gauge.

**4.2.6** Fire and explosions within a pressure system can cause pressure element failure with very violent effects, even to the point of completely disintegrating or melting the pressure gauge. Violent effects are also produced when failure occurs due to:

- (a) hydrogen embrittlement
- (b) contamination of a compressed gas
- (c) formation of acetylides
- (d) weakening of soft solder joints by steam or other heat sources
- (e) weakening of soft soldered or silver brazed joints caused by heat sources such as fires
- (f) corrosion
- (g) fatigue
- (h) mechanical shock
- (i) excessive vibration

Failure in a compressed gas system can be expected to produce violent effects.

**4.2.7 Modes of Elastic Element Failure.** There are four basic modes of elastic element failure, as follows.

**4.2.7.1 Fatigue Failure.** Fatigue failure caused by pressure induced stress generally occurs from the inside to the outside along a highly stressed edge radius, appearing as a small crack that propagates along the edge radius. Such failures are usually more critical with compressed gas media than with liquid media.

Fatigue cracks usually release the media fluid slowly so case pressure buildup can be averted by providing pressure relief openings in the gauge case. However, in high pressure elastic elements where the yield strength approaches the ultimate strength of the element material, fatigue failure may resemble explosive failure.

A restrictor placed in the gauge pressure inlet will reduce pressure surges and restrict fluid flow into the partially open Bourdon tube.

**4.2.7.2 Overpressure Failure.** Overpressure failure is caused by the application of internal pressure greater than the rated limits of the elastic element and can occur when a low pressure gauge is installed in a high pressure port of system. The effects of overpressure failure, usually more critical in compressed gas systems than in liquid filled systems, are unpredictable and may cause parts to be propelled in any direction. Cases with pressure relief openings will not always retain expelled parts.

Placing a restrictor in the pressure gauge inlet will not reduce the immediate effect of failure, but will help control flow of escaping fluid following rupture and reduce potential of secondary effects.

It is generally accepted that solid front cases with pressure relief back will reduce the possibility of parts being projected forward in the event of failure.

The window alone will not provide adequate protection against internal case pressure buildup, and can be the most hazardous component.

**4.2.7.3 Corrosion Failure.** Corrosion failure occurs when the elastic element has been weakened through the attack by corrosive chemicals present in either the media inside or the environment outside it. Failure may occur as pinhole leakage through the elements walls or early fatigue failure due to stress cracking brought about by chemical deterioration or embrittlement of the material.

A chemical (diaphragm) seal should be considered for use with pressure media that may have a corrosive effect on the elastic element.

**4.2.7.4 Explosive Failure.** Explosive failure is caused by the release of explosive energy generated by a chemical reaction such as can result with adiabatic compression of oxygen occurs in the presence of hydrocarbons. It is generally accepted that there is no known means of predicting the magnitude or effects of this type of failure. For this mode of failure, a solid wall or partition between the elastic element and the window will not necessarily prevent parts being projected forward.

**4.2.8 Pressure Connection.** See recommendations in para. 3.3.4.

### 4.3 Safety Recommendations.

**4.3.1 Operating Pressure.** The pressure gauge selected should have a full scale pressure such that the operating pressure occurs in the middle half (25 to 75%) of the scale. The full scale pressure of the gauge selected should be approximately two times the intended operating pressure.

Should it be necessary for the operating pressure to exceed 75% of full scale, contact the supplier for recommendations.

This does not apply to test, retarded, or suppressed scale gauges.

**4.3.2 Use of Gauges Near Zero Pressure.** The use of gauges near zero pressure is not recommended because the accuracy tolerance may be a large percentage of the applied pressure. If, for example, a 0/100 psi Grade B gauge is used to measure 6 psi, the accuracy of measurement will be  $\pm 50\%$  of the applied pressure. In addition, the scale of a gauge is often laid out with takeup, which can result in further inaccuracies when measuring pressures that are a small percentage of the gauge span.

For the same reasons, gauges should not be used for the purpose of indicating that the pressure in a tank, autoclave, or other similar unit has been completely exhausted to atmospheric pressure. Depending on the accuracy and the span of the gauge and the possibility that takeup is incorporated at the beginning of the scale, hazardous pressure may remain in the tank even though the gauge is indicating zero pressure. A venting device must be used to completely reduce the pressure before unlocking covers, removing fittings, or performing other similar activities.

**4.3.3 Compatibility With the Pressure Medium.** The elastic element is generally a thin walled member, which of necessity operates under high stress conditions and must, therefore, be carefully selected for compatibility with the pressure medium being measured. None of the common element materials is impervious to every type of chemical attack. The potential for corrosive attack is established by many factors, including the concentration, temperature, and contamination of the medium. The user should inform the gauge supplier of the installation conditions so that the appropriate element materials can be selected.

**4.3.4** In addition to the factors discussed above, the capability of a pressure element is influenced by the design, materials, and fabrication of the joints between its parts.

Common methods of joining are soft soldering, silver brazing, and welding. Joints can be affected by temperature, stress, and corrosive media. Where application questions arise, these factors should be considered and discussed by the user and manufacturer.

**4.3.5** Some special applications require that the pressure element assembly have a high degree of leakage integrity. Special arrangement should be made between manufacturer and used to assure that the allowable leakage rate is not exceeded.

### 4.3.6 Cases

**4.3.6.1 Cases, Solid Front.** It is generally accepted that a solid front case per para. 3.3.1 will reduce the possibility of parts being projected forward in the event of elastic element assembly failure. An exception is explosive failure of the elastic element assembly.

**4.3.6.2 Cases, Liquid Filled.** It has been general practice to use glycerine or silicone filling liquids. However, these fluids may not be suitable for all applications. They should be avoided where strong oxidizing agents including, but not limited to, oxygen, chlorine, nitric acid, and hydrogen peroxide are involved. In the presence of oxidizing agents, potential hazard can result from chemical reaction, ignition, or explosion. Completely fluorinated or chlorinated fluids, or both, may be more suitable for such applications.

The user shall furnish detailed information relative to the application of gauges having liquid filled cases and solicit the advice of the gauge supplier prior to installation.

Consideration should also be given to the instantaneous hydraulic effect that may be created by one of the modes of failure outlined in para. 4.2.7. The hydraulic effect due to pressure element failure could cause the window to be projected forward even when a case having a solid front is employed.

**4.3.7 Restrictor.** Placing a restrictor between the pressure connection and the elastic element will not reduce the immediate effect of failure, but will help control flow of escaping fluid following rupture and reduce the potential of secondary effects.

### 4.3.8 Specific Service Conditions

**4.3.8.1** Specific applications for pressure gauges exist where hazards are known. In many instances, requirements for design, construction, and use of gauges for these applications are specified by state or federal agencies or Underwriters Laboratories, Inc. Some of these specific service gauges are listed below. The list is not intended to include all types, and the user should always advise the supplier of all application details.

**4.3.8.2 Acetylene Gauges.** A gauge designed to indicate acetylene pressure. It shall be constructed using materials that are compatible with commercially available acetylene. The gauge may bear the inscription ACETYLENE on the dial.

**4.3.8.3 Ammonia Gauge.** A gauge designed to indicate ammonia pressure and to withstand the corrosive effects of ammonia. The gauge may bear the inscription AMMONIA on the dial. It may also include the equivalent saturation temperature scale markings on the dial.

**4.3.8.4 Chemical Gauge.** A gauge designed to indicate the pressure of corrosive or high viscosity fluids, or both. The primary material(s) in contact with the pressure medium may be identified on the dial. It may be equipped with a chemical (diaphragm) seal, pulsation damper, or pressure relief device, or a combination. These devices help to minimize potential damage to personnel and property in the event of gauge failure. They may, however, also reduce accuracy of sensitivity, or both.

**4.3.8.5 Oxygen Gauge.** A gauge designed to indicate oxygen pressure. Cleanliness shall comply with Level IV (see Section 5). The dial shall be clearly marked with a universal symbol and/or USE NO OIL in red color (see para. 6.1.2.1).

### 4.4 Reuse of Pressure Gauges

It is not recommended that pressure gauges be moved from one application to another. Should it be necessary, however, the following must be considered.

**4.4.1 Chemical Compatibility.** The consequences of incompatibility can range from contamination to explosive failure. For example, moving an oil service gauge to oxygen service can result in explosive failure.

**4.4.2 Partial Fatigue.** The first installation may involve pressure pulsation that has expended most of the gauge life, resulting in early fatigue in the second installation.

**4.4.3 Corrosion.** Corrosion of the pressure element assembly in the first installation may be sufficient to cause early failure in the second installation.

**4.4.4 Other Considerations.** When reusing a gauge, all guidelines covered in the Standard relative to application of gauges should be followed in the same manner as when a new gauge is selected.