

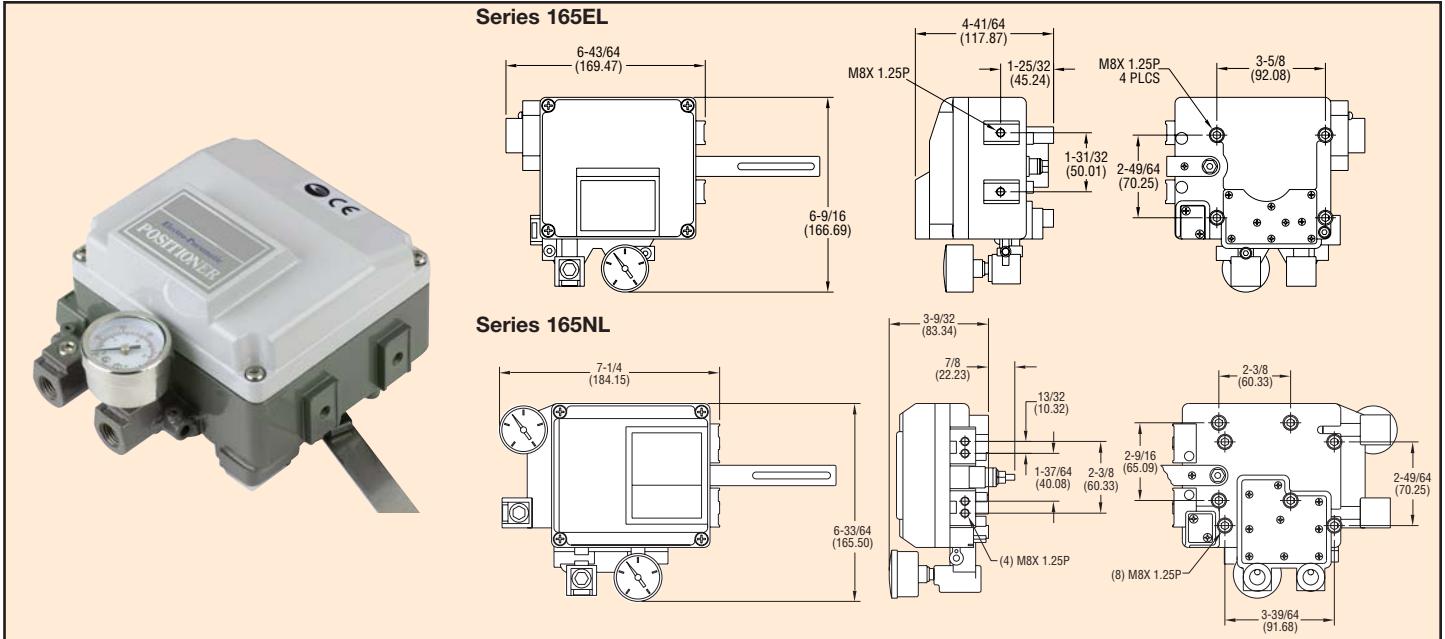

Series
165

PRECISOR® II Pneumatic and Electro-Pneumatic Positioners

Low Cost, Linear Operation, Field Selectable Cam Design



W.E. Anderson Series 165 PRECISOR® II Pneumatic and Electro-Pneumatic Positioners deliver stable process control at an exceptionally low price. Its rugged, durable design makes it ideal for harsh environments while maintaining precise, accurate positioning of the control element. Units can be easily changed from direct to reverse action, or vice versa. Low air consumption keeps operating costs at a minimum, while still responding quickly and accurately. Excellent for use in chemical processing, food and beverage, pulp and paper, and pharmaceutical industries, as well as many others.

MODELS

Model No.	Input
165NL	3-15 psig
165EL	4-20 mA

How To Order:

1. Select Model No. to specify input control signal
2. For proper mounting hardware, order according to which actuator the positioner will be mounted to:

Mounting Kits

Model Number	For Actuator Models
A-233	220 and 221 Air-to-Lower
A-234	222 and 223 Air-to-Lower
A-235	230 and 231 Air-to-Raise
A-236	233 Air-to-Raise

Valve Mount: For factory mounting and calibration to Hi-Flow™ control valves, add the position model number as a suffix to the valve part number. Example: 2004VA32-231-165NL

SPECIFICATIONS

Input Signal: Pneumatic: 3 to 15 psig (0.2 to 1 bar).
Electro-Pneumatic: 4-20 mA DC.

Input Impedance: (165EL only): 250 ±15 Ohm.

Material: Aluminum diecasting.

Air Supply: 20 to 100 psig (1.4 to 6.9 bar).

Air Supply Connection: 1/4" NPT.

Gage Connection: 1/8" NPT.

Electrical Connection: Screw terminal.

Conduit Connection: 1/2" NPT (165EL only).

Linearity: ±0.2% of full scale.

Hysteresis: 1% of full scale.

Sensitivity: ±0.2% of full scale.

Repeatability: ±0.5% of full scale.

Air Consumption: 0.10 scfm (3 LPM) at 20 psig (1.4 bar) supply.

Flow Capacity: 28 scfm (80 LPM) at 20 psig (1.4 bar) supply.

Stroke: 0.5 to 6" (10 to 150 mm).

Enclosure Rating: IP66.

Operating Temperature: -4 to 160°F (-20 to 70°C).

Weight: 165NL: 3.1 lb (1.7 kg).

165EL: 6.1 lb (2.7 kg).

Agency Approvals: CE (165EL only).

APPLICATIONS

Series 165 PRECISOR® II Pneumatic and Electro-Pneumatic Positioners provide excellent modulating control when used between the Dwyer Temperature Controllers, Current to Pressure Transducer and the Hi-Flow™ Valve in such industries as the food and beverage processing, chemical, pharmaceutical, and wood pulp and paper.

Suggested Specifications

Pneumatic and Electro-Pneumatic Positioners shall be cam characterized, with 0.5% full scale repeatability. The unit shall accept an input of 3-15 psig or 4-20 mA with capability of field-selectable modes of direct or reverse operation. Supply pressure shall be capable of 100 psig maximum. Unit shall be W.E. Anderson Series 165.