

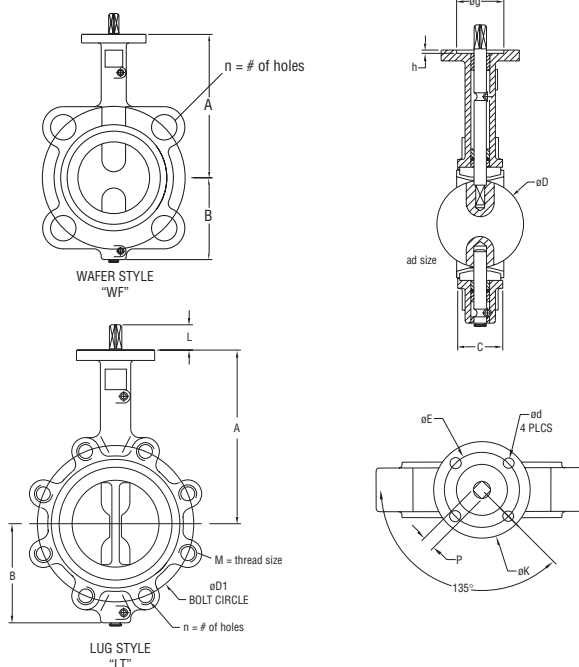

**Series BFV Butterfly Valves**  
**Specifications - Installation and Operating Instructions**



**Series BFV Butterfly Valves** are bi-directional allowing control of fluid flow and sealing in either direction, and are designed for installation between the faces of 125#/150# ANSI flanges. They do not require gaskets; the integral seat serves as the gasket. The wafer and lug bodies have bolt hole locations for alignment and attachment with mating flanges.

Prior to installation, close the valve. Spread the flanges apart far enough to allow the valve to slip easily between the flanges. Insert the valve between the flanges. Be sure to center the valve and not damage the liner. Allow the flanges to return to their un-spread state. Install and hand-tighten all flange bolts. Slowly open the valve, checking for free movement of the disc. If no obstruction is encountered, leave valve in the open position and tighten all flange bolts. Be certain to keep flange faces as parallel as possible during and after tightening bolts or studs. After final tightening, again check the valve for full opening and closing.

Lug style bodies used for dead end service must be installed as marked on the body (inlet-outlet).

**DIMENSIONS [in (mm)]**

Size	A	B	C	øD	øD1	n, WF	n, LT	M	øK	øE	ød	h	L	P	LO	ISO 5211
2"	6-11/32 (161.13)	3-5/32 (80.17)	1-21/32 (42.07)	2-5/64 (52.78)	4-3/4 (120.65)	4	4	5/8 (15.88)	3-1/32 (76.99)	1-31/32 (50.01)	9/32 (7.14)	1-25/64 (35.32)	1-17/64 (32.15)	23/64 x 23/64 (9.13 x 9.13)	10-41/64 (270.27)	F05
2-1/2"	6-57/64 (175.02)	3-33/64 (89.30)	1-49/64 (44.85)	2-35/64 (64.69)	5-1/2 (139.70)	4	4	5/8 (15.88)	3-1/32 (76.99)	1-31/32 (50.01)	9/32 (7.14)	1-25/64 (35.32)	1-17/64 (32.15)	23/64 x 23/64 (9.13 x 9.13)	10-41/64 (270.27)	F05
3"	7-9/64 (181.37)	3-3/4 (92.25)	1-25/32 (45.24)	3-7/64 (78.98)	6-1/16 (153.99)	4	4	5/8 (15.88)	3-1/32 (76.99)	1-31/32 (50.01)	9/32 (7.14)	1-25/64 (35.32)	1-17/64 (32.15)	23/64 x 23/64 (9.13 x 9.13)	10-41/64 (270.27)	F05
4"	7-7/8 (200.03)	4-1/2 (114.30)	2-1/16 (52.39)	4-7/64 (104.38)	7-1/2 (190.50)	4	8	5/8 (15.88)	3-35/64 (90.09)	2-49/64 (70.25)	23/64 (9.13)	2-11/64 (55.17)	1-17/64 (32.15)	7/16 x 7/16 (11.11 x 11.11)	10-41/64 (270.27)	F07
5"	8-25/64 (213.12)	5 (127)	2-5/32 (54.77)	4-55/64 (123.43)	8-33/64 (216.30)	8	8	3/4 (19.05)	3-35/64 (90.09)	2-49/64 (70.25)	23/64 (9.13)	2-11/64 (55.17)	1-17/64 (32.15)	9/16 x 9/16 (14.29 x 14.29)	10-41/64 (270.27)	F07
6"	8-29/32 (226.22)	5-31/64 (139.30)	2-13/64 (55.96)	6-9/64 (155.97)	9-33/64 (241.70)	8	8	3/4 (19.05)	3-35/64 (90.09)	2-49/64 (70.25)	23/64 (9.13)	2-11/64 (55.17)	1-17/64 (32.15)	9/16 x 9/16 (14.29 x 14.29)	10-41/64 (270.27)	F07
8"	10-1/4 (260.31)	6-57/64 (175.02)	2-25/64 (60.72)	7-63/64 (202.80)	11-49/64 (298.85)	8	8	3/4 (19.05)	4-59/64 (125.02)	4-11/64 (105.97)	9/16 (14.29)	2-49/64 (70.25)	1-25/32 (45.24)	43/64 x 43/64 (17.07 x 17.07)	14-3/16 (360.36)	F10
10"	11-1/2 (292.10)	8 (203.20)	2-19/32 (65.88)	9-7/8 (250.83)	14-17/64 (362.35)	12	12	7/8 (22.23)	4-59/64 (125.02)	4-11/64 (105.97)	9/16 (14.29)	2-49/64 (70.25)	1-25/32 (45.24)	7/8 x 7/8 (22.23 x 22.23)	19-11/16 (500.06)	F10
12"	13-9/32 (337.34)	9-17/32 (242.09)	3-1/32 (76.99)	11-7/8 (301.63)	17-1/64 (432.20)	12	12	7/8 (22.23)	5-33/64 (140.10)	4-11/64 (105.97)	9/16 (14.29)	2-49/64 (70.25)	1-25/32 (45.24)	7/8 x 7/8 (22.23 x 22.23)	19-11/16 (500.06)	F10

**SPECIFICATIONS**

- VALVE BODY**
- Service:** Compatible liquids, gases, and steam.
- Line Size:** 2" to 12".
- Body Style:** 2-way, wafer, or lug butterfly.
- End Connections:** Flange, to be used with flanges that are ANSI Class 125 (B16.1) and ANSI Class 150 (B16.5) dimensions.
- Pressure Limit:** 225 psi (15.5 bar) WOG.

**Wetted Materials:**

- Body Material:** Ductile iron.
- Disc:** 316 SS.
- Seat and O-ring:** EPDM or PTFE.
- Stem:** 410 SS.
- Temperature Limits:** Disc: EPDM: -50 to 250°F (-46 to 121°C). PTFE: 0 to 300°F (-18 to 149°C).
- Bearings:** Nylatron.
- Flow Rate:** See Cv chart.
- Operator:** 2 to 6": 10-position locking hand lever. 8 to 12": manual gear.

## VALVE DISASSEMBLY

1. After removal of valve from the piping system, open the valve fully;
2. Remove the handle or actuator;
3. Remove the stem retaining pins;
4. Pull out the upper stem;
5. Pull out the bottom stem;
6. Remove the disc from the liner. Do not damage the disc edge;
7. Remove the liner;
8. If the valve has bushings and o-rings, remove by tapping with blunt instrument;
9. Inspect all components for wear and replace as required.

## VALVE ASSEMBLY

1. Clean all reusable parts;
2. If valve has bushings and o-rings, tap them carefully;
3. Apply a lubricant or soapy solution compatible with elastomers to facilitate assembly;
4. Insert liner into body by pressing it into the body evenly;
5. Insert disc in open position into liner. Make certain beveled end of disc is at the upper stem end of the body;
6. Coat the upper stem with a general purpose lubricant & install into body;
7. Install bottom stem;
8. Install retaining pins to both stems;
9. Install the operator;
10. Check assembly by opening & closing the valve several times;
11. Follow installation instructions for reinstalling the valve in the piping system.

## MAINTENANCE

No regular maintenance or lubrication is required.

## WARRANTY

The Series BFV Butterfly Valve is warranted from defects in materials and workmanship for (1) year from the date of purchase. In the unlikely event the valve should fail, the unit can be returned to the factory for warranty repair if the warranty period has not expired. Contact our customer service department for an RGA number and to set up the return.

### HAND LEVER "HL"

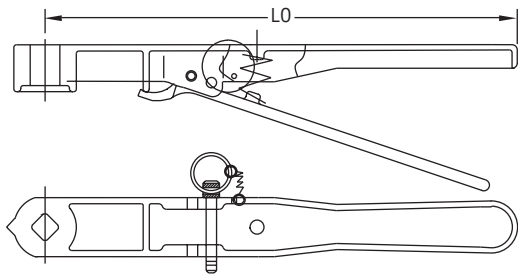

### HAND LEVER DIMENSIONS [in (mm)]

Size	2"	2-1/2"	3"	4"	5"	6"
LO	10-41/64 (270.27)	10-41/64 (270.27)	10-41/64 (270.27)	10-41/64 (270.27)	10-41/64 (270.27)	10-41/64 (270.27)

## BREAK TORQUES IN INCH-POUNDS

EPDM Seats	Size (inches)									
	2	2-1/2	3	4	5	6	8	10	12	
Service Pressure	2	2-1/2	3	4	5	6	8	10	12	
50 psi	86	126	179	295	540	750	1440	2466	3510	
100 psi	108	144	195	310	610	780	1490	2910	4100	
150 psi	126	150	210	335	699	847	1549	3360	5560	
200 psi	150	198	297	400	725	940	1800	3890	7558	

PTFE Seats	Size (inches)									
	2	2-1/2	3	4	5	6	8	10	12	
Service Pressure	2	2-1/2	3	4	5	6	8	10	12	
50 psi	125	130	195	390	650	890	1690	3699	5265	
100 psi	130	145	210	430	690	940	1710	4365	6150	
150 psi	142	160	248	443	720	974	1770	5040	8340	
200 psi	180	220	340	490	795	1020	1890	5835	11367	

## Cv VALUES

Size	DEGREE OPENING									FULL OPEN
	10°	20°	30°	40°	50°	60°	70°	80°	90°	
2"	0.1	5	12	24	45	64	90	125	135	
2-1/2"	0.2	8	20	37	65	98	144	204	220	
3"	0.3	12	22	39	70	116	183	275	302	
4"	0.5	17	36	78	139	230	364	546	600	
5"	0.8	29	61	133	237	392	620	930	1022	
6"	2	45	95	205	366	605	958	1437	1579	
8"	3	89	188	408	727	1202	1903	2854	3136	
10"	4	151	320	694	1237	2047	3240	4859	5340	
12"	5	234	495	1072	1911	3162	5005	7505	8250	

Cv is the number of U.S. GPM of 60°F water that will pass through the valve with a 1 PSI pressure drop.

### MANUAL GEAR "MG"

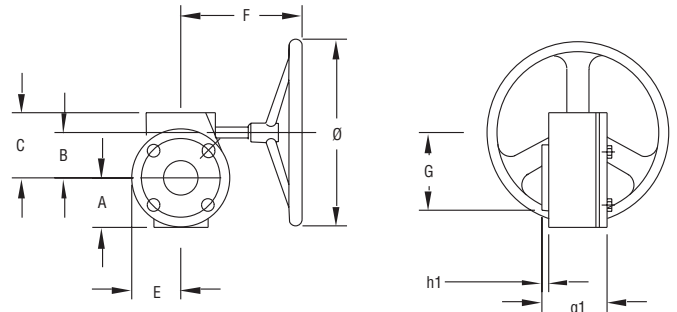

### MANUAL GEAR DIMENSIONS [in (mm)]

Size	A	B	C	E	F	G	Ø	g1	h1
8"-10"	2-61/64 (75)	2-31/64 (63.10)	3-63/64 (101.20)	2-61/64 (75)	9-27/32 (250.03)	3-25/64 (86.12)	11-13/16 (300.04)	2-49/64 (70.25)	1/8 (3.18)
12"	3-13/64 (81.36)	3-5/32 (80.17)	4-21/32 (118.27)	3-13/64 (81.36)	8-15/16 (227.01)	3-9/32 (83.34)	11-13/16 (300.04)	2-49/64 (70.25)	1/8 (3.18)

### FIGURE 1

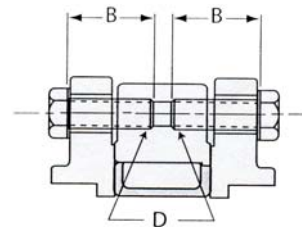

### LUG RECOMMENDED FLANGE BOLT LENGTHS (Fig. 1)

DIM	Valve Size (inches)									
	2	2-1/2	3	4	5	6	8	10	12	
B	1-1/2	1-1/2	1-1/2	1-3/4	1-3/4	2	2	2-1/4	2-1/2	
D	5/8	5/8	5/8	5/8	3/4	3/4	3/4	7/8	7/8	
	-11UNC	-11UNC	-11UNC	-11UNC	-10UNC	-10UNC	-10UNC	-9UNC	-9UNC	