



Series DCV/RDCV Diaphragm Valves

Specifications - Installation and Operating Instructions



DCV62T1D



DCV20C1D



RDCV62T



RDCV20C

The Series DCV/RDCV Dust Collection Valves are ideal for use with the Series DCT1000 and Series DCT500 duct collection timer boards. Both the Series DCV and RDCV have the option for either coupling or NPT connections. The coupling connection allows for a quick and simple installation. Only the stub pipe and blowtube need to be cleaned and deburred before the valve is fit into position. The "T" Series DCV has female threaded connections. Both the "C" and "T" versions have a 90° angle between the inlet and outlet the most suitable configuration for pulse valve applications. The design offers not only ease of installation, but also minimal airflow restriction for an exceptional cleaning pulse. The valves are offered in both integrated and remote coil configurations.

SPECIFICATIONS

Service: Compatible gases, filtered and oil free.

Wetted Materials: Body: aluminum; Trim: 304 SS; Diaphragm and seals: NBR; Diaphragm disc: polyamide.

Other Materials: Cover: aluminum; Body bolts and spring: 304 SS.

Pressure Limits: Minimum of 4.4 psi (0.3 bar), maximum of 124.7 psi (8.6 bar).

Temperature Limits: Ambient: -4 to 140°F (-20 to 60°C) for RDCV models, -4 to 122°F (-20 to 50°C) for DCV models; Operating: -4 to 185°F (-20 to 85°C).

Power Requirements: 110 VAC, 220 VAC, or 24 VDC for DCV models.

Power Consumption: 12 W, inrush: 17 VA; holding: 14.5 VA for DCV models.

Electrical Connection: DIN connection for DCV models.

Enclosure Rating: NEMA 4X (IP65) for DCV models.

Process Connection: See model chart.

Mounting Orientation: Any position.

MODELS

Model Number	Size	Solenoid	Connection	Number of Diaphragms	Cv Factor (gal/min)
RDCV20T	3/4"	Remote	NPT	1	14
RDCV20C		Remote	Coupling		
DCV20T1D		Integral*	NPT		
DCV20C1D		Integral*	Coupling		
RDCV25T	1"	Remote	NPT	1	23
RDCV25C		Remote	Coupling		
DCV25T1D		Integral*	NPT		
DCV25C1D		Integral*	Coupling		
RDCV35T	1-1/2"	Remote	NPT	1	42
RDCV35C		Remote	Coupling		
DCV35T1D		Integral*	NPT		
DCV35C1D		Integral*	Coupling		
RDCV45T	1-1/2"	Remote	NPT	2	51
RDCV45C		Remote	Coupling		
DCV45T1D		Integral*	NPT		
DCV45C1D		Integral*	Coupling		
RDCV50T	2"	Remote	NPT	2	106
DCV50T1D		Integral*	NPT		
RDCV62T	2-1/2"	Remote	NPT	2	136
DCV62T1D		Integral*	NPT		
RDCV76T	3"	Remote	NPT	2	167
DCV76T1D		Integral*	NPT		

* 110 VAC with DIN Connector

Series DCV/RDCV Model Guide

Construction	DCV	RDCV				Integrated Coil	Remote Coil
Size		20 25 35 45 50 62 76				3/4" 1" 1-1/2" 1-1/2" (2 Diaphragms) 2" 2-1/2" 3"	
Connection			T C			NPT Coupling (up to 1-1/2" only)	
Voltage				1 2 3		110 VAC (for integrated coil only) 220 VAC (for integrated coil only) 24 VDC (for integrated coil only)	
Electrical Connections					D	DIN (for integrated coil only)	

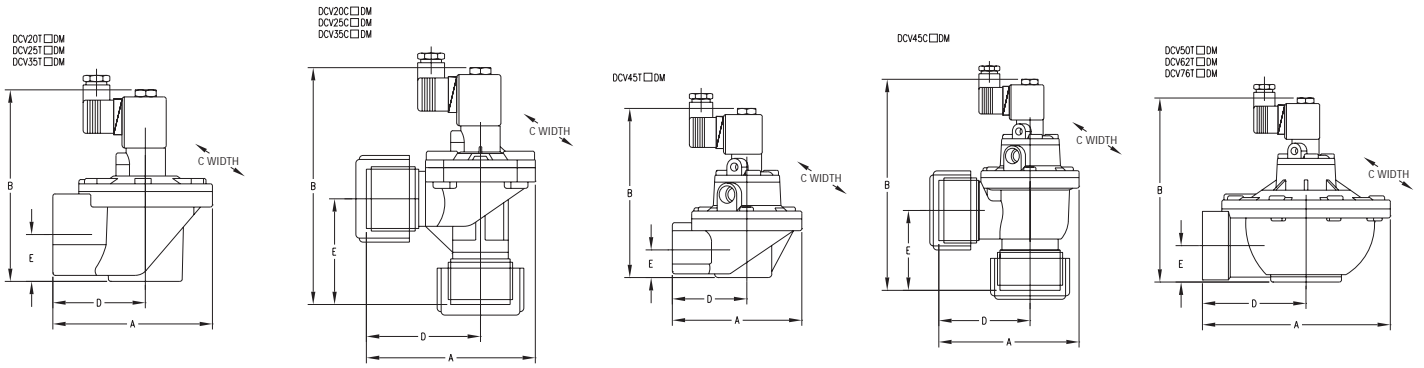

DCV DIMENSIONAL CHART

Connection	Model Number						A (A mm)	B (B mm)	C (C mm)	D (D mm)	E (E mm)
	DIN Electrical Connection			Lead Wires Electrical Connection							
NPT	DCV20T1D	DCV20T2D	DCV20T3D	DCV20T1L	DCV20T2L	DCV20T3L	3-15/16" (100)	4-13/16" (122)	3-7/16" (87)	2-3/16" (56)	25/32" (20)
	DCV25T1D	DCV25T2D	DCV25T3D	DCV25T1L	DCV25T2L	DCV25T3L	4-1/8" (105)	4-21/32" (126)	3-1/4" (83)	2-1/2" (64)	7/8" (22)
	DCV35T1D	DCV35T2D	DCV35T3D	DCV35T1L	DCV35T2L	DCV35T3L	5-1/8" (130)	6-1/16" (154)	4-3/8" (111)	4-1/2" (114)	1-9/32" (33)
	DCV45T1D	DCV45T2D	DCV45T3D	DCV45T1L	DCV45T2L	DCV45T3L	5-25/32" (147)	7-7/32" (183)	4-3/8" (111)	3-5/8" (91)	3" (76)
	DCV50T1D	DCV50T2D	DCV50T3D	DCV50T1L	DCV50T2L	DCV50T3L	8-1/16" (205)	7-29/32" (201)	7-1/4" (184)	4-15/32" (113)	1-9/16" (40)
	DCV62T1D	DCV62T2D	DCV62T3D	DCV62T1L	DCV62T2L	DCV62T3L	8-9/32" (210)	8-3/4" (222)	7-1/4" (184)	4-21/32" (118)	1-29/32" (48)
	DCV76T1D	DCV76T2D	DCV76T3D	DCV76T1L	DCV76T2L	DCV76T3L	8-19/32" (218)	9-7/8" (251)	7-7/8" (200)	4-21/32" (118)	2-1/2" (63)
Coupling	DCV20C1D	DCV20C2D	DCV20C3D	DCV20C1L	DCV20C2L	DCV20C3L	4-13/32" (112)	5-27/32" (148)	3-7/16" (87)	2-5/8" (67)	1-25/32" (45)
	DCV25C1D	DCV25C2D	DCV25C3D	DCV25C1L	DCV25C2L	DCV25C3L	4-5/8" (117)	6-21/32" (177)	3-1/4" (83)	3" (76)	2-3/4" (70)
	DCV35C1D	DCV35C2D	DCV35C3D	DCV35C1L	DCV35C2L	DCV35C3L	5-13/16" (147)	7-21/32" (194)	4-3/8" (111)	3-5/8" (91)	3" (76)
	DCV45C1D	DCV45C2D	DCV45C3D	DCV45C1L	DCV45C2L	DCV45C3L	5-25/32" (147)	8-27/32" (224)	4-3/8" (111)	3-5/8" (91)	3" (76)

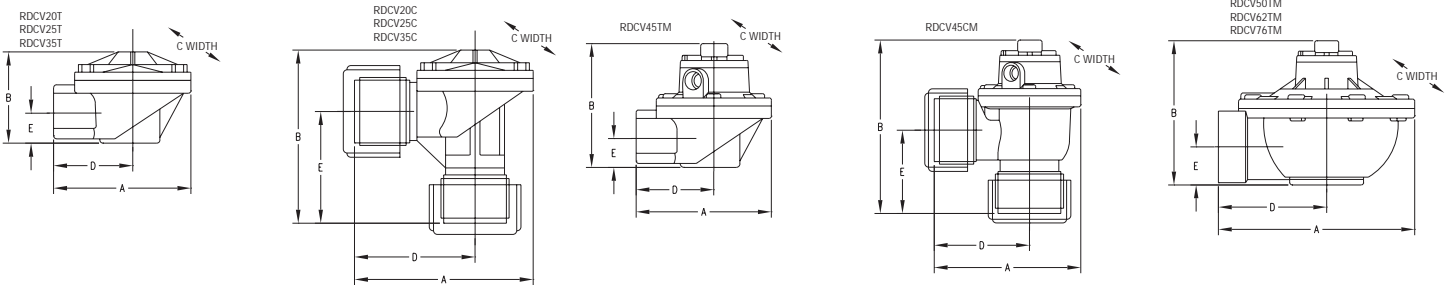

RDCV DIMENSIONAL CHART

Connection	Model Number	A (A mm)	B (B mm)	C (C mm)	D (D mm)	E (E mm)
NPT	RDCV20T	3-15/16" (100)	2-31/32" (75)	3-7/16" (87)	2-3/16" (56)	25/32" (20)
	RDCV25T	4-1/8" (105)	3" (76)	3-1/4" (83)	2-1/2" (64)	7/8" (22)
	RDCV35T	5-1/8" (130)	4-29/32" (125)	4-3/8" (111)	4-1/2" (114)	1-9/32" (33)
	RDCV45T	5-25/32" (147)	5-5/32" (131)	4-3/8" (111)	3-5/8" (91)	3" (76)
	RDCV50T	8-1/16" (205)	5-7/8" (149)	7-1/4" (184)	4-15/32" (113)	1-9/16" (40)
	RDCV62T	8-9/32" (210)	6-11/16" (170)	7-1/4" (184)	4-21/32" (118)	1-29/32" (48)
	RDCV76T	8-19/32" (218)	7-27/32" (199)	7-7/8" (200)	4-21/32" (118)	2-1/2" (63)
Coupling	RDCV20C	4-13/32" (112)	4" (102)	3-7/16" (87)	2-5/8" (67)	1-25/32" (45)
	RDCV25C	4-5/8" (117)	5" (127)	3-1/4" (83)	3" (76)	2-3/4" (70)
	RDCV35C	5-13/16" (147)	5-15/32" (139)	4-3/8" (111)	3-5/8" (91)	3" (76)
	RDCV45C	5-25/32" (147)	6-25/32" (172)	4-3/8" (111)	3-5/8" (91)	3" (76)

OPERATION

Series DCV includes an integral solenoid and Series RDCV needs to be used with a remote pilot solenoid valve. Both are normally closed valves. When the remote pilot solenoid valve or integral solenoid opens, pressure is released (exhausted) from the top of the diaphragm in the pulse valve. This allows the line pressure on the bottom of the diaphragm to push the diaphragm up and open the main orifice of the pulse valve. When the solenoid then closes the pressure on the bottom and the top of the diaphragm equalize closing the main orifice of the pulse valve.

INSTALLATION



Warning: Before installation make sure all air pressure has been released, electric power has been turned off, and air pressure source has been closed. Turn power on and increase pressure only after installation is complete.

LOCATION

Select a location that will not exceed the ambient temperature specifications of the valve. The system must be located in an enclosure that meets relevant safety standards and electrical codes of the environment.

MOUNTING

The DCV/RDCV can be mounted in any position. For optimum life and performance it is recommended that the unit be mounted vertically and upright to reduce the chance of foreign matter accumulating in the valve. For DCV in weatherproof applications it is recommended that the cable gland be positioned face down to avoid possible rainfall or water from entry.

PROCESS CONNECTIONS

For DCV/RDCV with coupling connections:

1. Connect piping so that pneumatic input is the bottom connection and the outlet is the side connection at 90°.
2. Stub pipe (blow tube) must be free of burrs, rust, oil, and other debris.
3. Disassemble compression fittings and place the retaining nut, retainer, and gasket onto the piping. Make sure that the beveled edge of the gasket faces the valve body.
4. Connect fittings to the valve body. Make sure that the pipe is inline with the valve ports. Nut and seals are for connection only and should not be used for support purposes.

Notes:

- Make sure pipes are anchored securely to avoid separation from the valve.
- Do not use the valve for leverage when connecting piping.
- Do not over-tighten retaining nut or valve damage may result. Tighten retaining nuts just sufficiently for sealing to prevent leakage. This is a gasket seal and does not require excessive turning of the nut.

For DCV/RDCV with NPT connections:

1. Connect piping so that pneumatic input is the bottom connection and the outlet is the side connection at 90°.
2. Stub pipe (blow tube) must be free of burrs, rust, oil, and other debris.
3. Thread piping into the valve body. Make sure that the pipe is inline with the valve ports. If using tape or pipe compound, apply to the male piping threads and use sparingly as it may come loose and affect valve operation. Do not apply tape or pipe compound directly to the female valve body threads.

Notes:

- Make sure pipes are anchored securely.
- Do not use the valve for leverage when connecting piping.

Pressure Connection from Remote Pilot Solenoid Valve (For RDCV units)

The RSV, remote pilot solenoid valve, should be mounted as close as possible to the RDCV pulse valve. The maximum distance is 9.8 ft (3 m). Tubing from the remote solenoid valve is connected to the exhaust port on the top of the RDCV pulse valve. If using tape or pipe compound, apply to the male piping threads and use sparingly as it may come loose and affect valve operation. Do not apply tape or pipe compound directly to the female valve body threads.

Wiring Connections (For DCV units)

Wire in accordance with the National Electrical Code and local regulations. To aid in wiring the solenoid on the DCV may be rotated 360°. It is recommended to use 18 AWG copper wire rated at 90°C or greater.

Wiring the DCV with DIN connector. See Figure 1.

1. Remove center screw and pull wiring assembly from the body.
2. Remove gasket and place small screwdriver in slot to pry out the terminal block from the cover.
3. Thread wire through the gland nut, gland gasket, washer and connector cover.
4. Connect wires to proper terminals on the terminal block.
5. Snap terminal block back into the cover. The connector cover may be rotated in 90° increments to position the cable entry as needed for the application. Reinstall the center screw and screw back into the solenoid body.

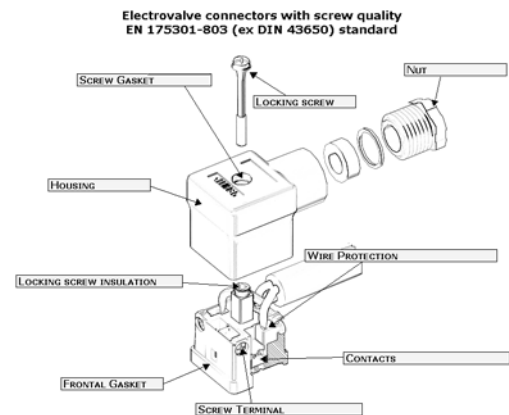

Figure 1

Solenoid Valve Troubleshooting

Problem	Possible Cause	Action Required
No pulse	No supply air	Check whether the air compressor and valve have been turned on
	Air pressure is too high	Check the pressure of the air supply
	No voltage to RSV	Check supply voltage
	Solenoid is damaged	Send back for evaluation
Leakage in outlet port	Improper installation of inlet port	Check the pipe connections between the inlet and outlet
Low pulse	Low air pressure	Check air supply pressure
		Verify that the air supply was distributed properly
Shaking noise	Valve screws are loose	Tighten the loose screws
Solenoid noise	Solenoid mounting screws are loose	Tighten the loose screws

MAINTENANCE

Warning: To prevent the possibility of death, serious injury or property damage, turn off electrical power, depressurize system and unit, and vent fluid to a safe area before servicing.

The DCV/RDCV should be cleaned periodically. The amount of time between cleanings depends on the application. Preventive Maintenance includes keeping media clean of material and oil free, and periodic testing to ensure proper operation and to look for wear or damage. Replacement diaphragm assemblies are available from the factory.

WARRANTY

The Series DCV/RDCV is not field serviceable and should be returned if repair is needed (field repair should not be attempted and may void warranty). Be sure to include a brief description of the problem plus any relevant application notes. Contact customer service to receive a return goods authorization number before shipping.