



LIN-E-AIRE® Valve Actuators

Specifications - Installation and Operating Instructions

Push-to-Close

Termination Nos. 220 thru 223, 240 thru 244

Push-to-Open

Termination Nos. 230, 231, 233, 250 thru 254



Push-to-Close



Push-to-Open

NOTICE: Information in this manual is intended only to assist our customers in the efficient operation of our equipment. Use of this manual for any other purpose is specifically prohibited and its contents are not to be reproduced in full or part without prior approval.

Use of the DANGER, WARNING, CAUTION and NOTE

This publication includes DANGER, WARNING, CAUTION and NOTE information where appropriate to point out safety related or other important information.

DANGER - Hazards which will result in severe personal injury or death.

WARNING - Hazards which could result in personal injury.

CAUTION - Hazards which could result in equipment or property damage.

NOTE - Alerts user to pertinent facts and conditions.

Although DANGER and WARNING hazards are related to personal injury, and CAUTION hazards are associated with equipment or property damage, it should be understood that operation of damaged equipment could, under certain operational conditions, result in degraded process system performance leading to personal injury or death. Therefore, comply fully with all DANGER, WARNING, and CAUTION notices.

TABLE OF CONTENTS

1 INTRODUCTION	3
1.1 Description	3
1.2 Catalog Numbers	4
1.3 Specifications	5
2 INSTALLATION	5
2.1 Mounting	5
2.2 Pneumatic Connections	5
3 OPERATION	6
3.1 Checking Valve Travel	6
3.2 Adjusting Actuator Range	7
3.2.1 Air-to-Lower Actuator	7
3.2.2 Air-to-Raise Actuator	7
4 MAINTENANCE	8
4.1 Test Equipment and Tools Required	8
4.2 Adjusting Valve Plug Travel	8
4.2.1 Push-to-Close Valve with Air-to-Lower Actuator	8
4.2.2 Push-to-Close Valve with Air-to-Raise Actuator or Push-to-Open Valve with Air-to-Lower Actuator	8
4.3 Replacing Actuator Diaphragm	8
4.3.1 Air-to-Lower Actuator	8
4.3.2 Air-to-Raise Actuator	9
4.4 Changing Range Spring	9
4.4.1 Air-to-Lower Actuator	9
4.4.2 Air-to-Raise Actuator	9

ILLUSTRATIONS

Fig. 1 Air-to-Lower Actuator	3
Fig. 2 Air-to-Raise Actuator	3
Fig. 3 Mounting Dimensions for Air-to-Lower Actuator	6
Fig. 4 Mounting Dimensions for Air-to-Raise Actuator	6
Fig. 5 Travel Indicator Plate Showing Valve Plug Travel	6
Fig. 6 Adjusting Actuator Range	7
Fig. 7 Adjusting Valve Plug Travel	8
Fig. 8 Disassembly of Air-to-Lower Actuator	10
Fig. 9 Disassembly of Air-to-Raise Actuator	11

TABLES

1 Air-to-Lower Actuator	5
2 Air-to-Raise Actuator	5
3 Maximum Air Supply Pressure and Maximum Stroke	5
4 Tools Required	8

1. INTRODUCTION

1.1 DESCRIPTION

The **Lin-E-Aire®** Valve Actuators are used for automatic operation of the control valve. The opening, closing or throttling of the valve plug in the valve body is accomplished by varying the air pressure to the diaphragm in the actuator. This pressure is transmitted from a control device, which may be controlling pressure, liquid level, temperature or flow.

Two types of actuators are used for process control, the choice of either depends upon the valve action desired in case of air supply failure. There are two types

Air-to-Lower - Termination Nos. 220 thru 223, 240 thru 244, Figure 1. In this type of actuator, air pressure moves the push rod downward compressing the spring. In the event of air failure, the push rod moves to its extreme upward position.

Air-to-Raise - Termination Nos. 230, 231, 233, 250 thru 254, Figure 2. In this type of actuator, air pressure moves the push rod upward compressing the spring. In the event of air failure, the push rod moves to its extreme downward position.

Thus, by selection of actuator and control valve plug action, either push-to-close or push-to-open, the control valve will either open or close on failure of air pressure to diaphragm.

The spring and diaphragm are completely enclosed to protect them from dust, dirt and other foreign matter. Spring adjustments are made with a ball bearing spring adjustment sleeve. Diaphragm and spring assembly may easily be removed for replacement or substitution.

The construction and operating range are listed on the data plate mounted on actuator. Actuator size and spring are selected to meet the requirements of the application. In service the actuator should create full travel of the valve plug when the pressure range indicated on data plate is applied. This pressure range is most generally 3 to 15 psi (20 to 100 kPa), but other ranges are available.

For precise control of valve plug position or where two valves are to be operated in sequence by one control device, a W.E. Anderson valve positioner, Catalog Number 100N or 165, is recommended.

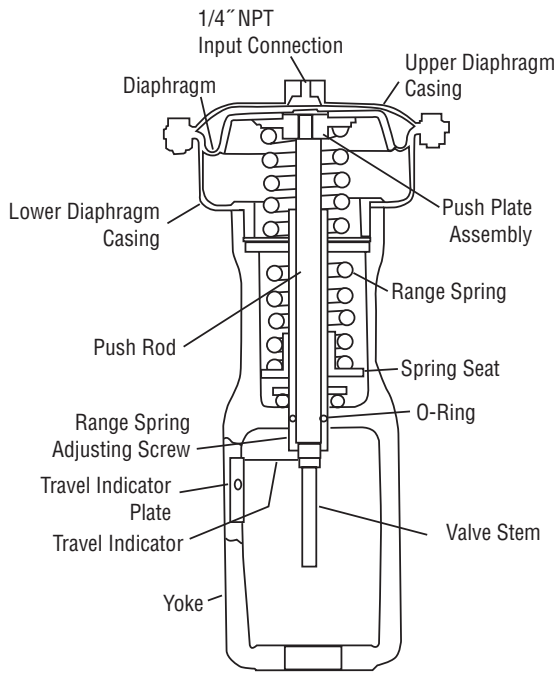

Figure 1. Air-to-Lower Actuator

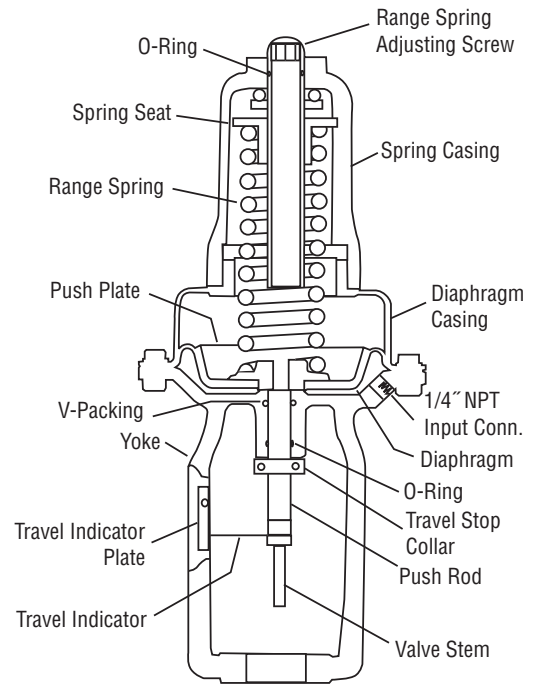

Figure 2. Air-to-Raise Actuator

1.2 Catalog Numbers

Control Valves - Hi-Flow™ Series Model Chart

Example	2	00	1	V	A	3	2	230		LO	2001VA32-230-LO Hi-Flow™ Globe Valve; 2-way, 3/4" NPT connection, linear plug, bronze body, 316 SS trim, reduced port 1/2" size.
Configuration	2 3										2-way 3-way
Valve Body Action		00 01									Push-To-Close Push-To-Open (2-way only)
Connection Size			0 1 2 3 4 5 6 7 8								1/2" NPT 3/4" NPT 1" NPT 1-1/4" NPT 1-1/2" NPT (or Flange with LRF or HRF option) 2" NPT (or Flange with LRF or HRF option) 2-1/2" Flange (see options) 3" Flange (see options) 4" Flange (see options)
Valve Seat				V W							Single Seat (2-way only) Double Seat (3-way only)
Valve Plug Type					A L S N						Linear Linear Needle (2000 to 2002 only) Equal Percentage (2000 to 2005 only) Equal Percentage Needle (2000 to 2002 only)
Valve Body Material						1 3 4					Ductile Iron Bronze 316 SS
Trim Material							2				316 SS
Actuator								220 221 222 223 230 231 233			Air-To-Lower, 20 in ² Air-To-Lower, 45 in ² Air-To-Lower, 45 in ² Air-To-Lower, 80 in ² Air-To-Raise, 20 in ² (2-way only) Air-To-Raise, 45 in ² (2-way only) Air-To-Raise, 80 in ² (2-way only)
Needle Plug Port Size									2 3 4 5 6 7 8 9		1/8" for Type N valve plug 3/16" for Type N valve plug 1/4" for Type N valve plug 5/16" for Type N valve plug 3/8" for Type N valve plug 1/32" for Type L valve plug 1/16" for Type L valve plug 3/32" for Type L valve plug
Options										A LO L1 Z LRF HRF	Positioner factory mounted (specify positioner model) Reduced port: 3/4" to 1/2" port size (2001 only) Reduced port: 1" to 1/2" port size (2002 only) Reduced port: 1" to 3/4" port size (2002 only) Special operating range (2-10 psi, 10-18 psi) Low Range Flange: Class 125 in Iron or Class 150 Bronze, 316 SS body (for 1-1/2" and 2" sizes only, standard on 2-1/2", 3, and 4" size) High Range Flange: Class 250 in Iron or Class 300 in Bronze, 316 SS body (for 1-1/2" to 4" sizes)

1.3 Specifications

Table 1. Air-to-Lower Actuator

Boss Dia.	Standard Actuator				Senior Actuator			
	Term. No.	Part No.	No. of Bolts	Effective Area	Term. No.	Part No.	No. of Bolts	Effective Area
1-1/2"	220	15S620	10	20 sq. in.	221	15S621	12	45 sq. in.
1-15/16"	222	15S622	12	45 sq. in.	223	15S623	18	80 sq. in.
2-1/8"	240	15S640	12	20 sq. in.	241	15S641	12	45 sq. in.
2-13/16"	242	15S642	12	45 sq. in.	243	15S643	18	80 sq. in.
2-13/16"	244	15S644	18	80 sq. in.	-	-	-	-

Table 2. Air-to-Raise Actuator

Boss Dia.	Standard Actuator				Senior Actuator			
	Term. No.	Part No.	No. of Bolts	Effective Area	Term. No.	Part No.	No. of Bolts	Effective Area
1-1/2"	230	15S630	10	20 sq. in.	231	15S631	12	45 sq. in.
1-15/16"	-	-	-	-	233	15S633	18	80 sq. in.
2-1/8"	250	15S650	10	20 sq. in.	251	15S651	12	45 sq. in.
2-13/16"	252	15S652	12	45 sq. in.	253	15S653	18	80 sq. in.
2-13/16"	254	15S654	18	80 sq. in.	-	-	-	-

ACTUATOR MATERIALS

Frame: Cast Iron, Baked Enamel Finish.

Diaphragm Case: Steel, Baked Enamel Finish.

Diaphragm: Buna-N-rubber, Nylon reinforced.

Range Spring: Plated spring steel.

Range Spring Seat: Plated steel.

Adjusting Screw: Plated cold rolled steel.

Push Rod: Plated steel.

AMBIENT TEMPERATURE LIMITS

-32 to 150°F (-36 to 66°C).

MAXIMUM ACTUATOR AIR PRESSURE

Refer to Table 3.

AIR CONNECTION: 1/4" female NPT.

MAXIMUM STROKE

Refer to Table 3.

Table 3. Maximum Air Supply Pressure and Maximum Stroke

Termination Number	Part No.	Max. Air Supply Pressure		Max. Stroke		
		Standard	psig	kPa	Inches	mm
Air-to-Lower	220	15S620	100	700	1	25.4
	240	15S640	100	700	1	25.4
	221	15S621	50	350	1	25.4
	241	15S641	50	350	1	25.4
	222	15S622	100	700	1-1/2	38.1
	242	15S642	100	700	1-1/2	38.1
	223	15S623	50	350	1-1/2	38.1
	243	15S643	50	350	1-1/2	38.1
	244	15S644	70	480	2-1/4	57.2
Air-to-Raise	230	15S630	100	700	1	25.4
	250	15S650	100	700	1	25.4
	231	15S631	50	350	1	25.4
	233	15S633	50	350	1-1/2	38.1
	251	15S651	50	350	1	25.4
	252	15S652	100	700	1-1/2	38.1
	253	15S653	50	350	1-1/2	38.1
	254	15S654	70	480	2-1/4	57.2

2. INSTALLATION

2.1 Mounting - The Lin-E-Aire Valve Actuator is normally furnished mounted on a valve body. Follow the valve body instructions when installing the control valve in the pipeline.

Clearance should be left above and below the control valve to permit removal of actuator and valve plug. Removal clearance dimensions are specified in the control valve instructions, as well as installation instructions. The actuator will sometimes be shipped alone for field mounting on a valve body. Mount actuator as outlined in the control valve instructions.

2.2 Pneumatic Connections - Connect the input pressure to the 1/4" female NPT port on the top of an air-to-lower actuator or under the diaphragm casing on an air-to-raise actuator, Figure 3 or 4. Either pipe or tubing may be used for the air line. The input pressure must not exceed the limits listed under the specifications.

When there is a long distance between the actuator and the control device which produces the input pressure, or when a large actuator size is required, there may be excessive transmission lag in the control signal. A W.E. Anderson Valve Positioner, Catalog Number 100N or 165, can be used to reduce the lag. If a valve positioner is included with the actuator, connections between the positioner and actuator are made at the factory. Refer to the valve positioner instructions for additional connection information.

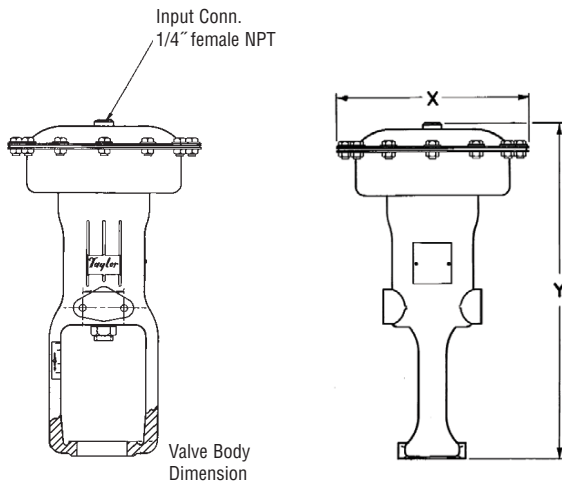

Figure 3. Mounting Dimension for Air-to-Lower Actuator
Standard Actuator in. (mm)

Term No.	Part No.	X	Y	No. of Bolts	Yoke Boss Hole Diam.
220	15S620	7-3/4 (196.85)	15-7/8 (403.23)	10	1-1/2 (38.10)
222	15S622	10-5/8 (269.86)	18-5/8 (473.08)	12	1-15/16 (49.21)
240	15S640	7-3/4 (196.85)	15-7/8 (403.23)	10	2-1/8 (53.98)
242	15S642	10-5/8 (269.86)	18-5/8 (473.08)	12	2-13/16 (71.44)
244	15S644	13-3/8 (339.73)	22-5/8 (574.68)	18	2-13/16 (71.44)

Senior Actuator in. (mm)

Term No.	Part No.	X	Y	No. of Bolts	Yoke Boss Hole Diam.
221	15S621	10-5/8 (269.86)	16-9/16 (420.69)	12	1-1/2 (38.10)
223	15S623	13-3/8 (339.73)	20 (508.00)	18	1-15/16 (49.21)
241	15S641	10-5/8 (269.86)	16-9/16 (420.69)	12	2-1/8 (53.98)
243	15S643	13-3/8 (339.73)	20 (508.00)	18	2-13/16 (71.44)

For reference only; not for construction.

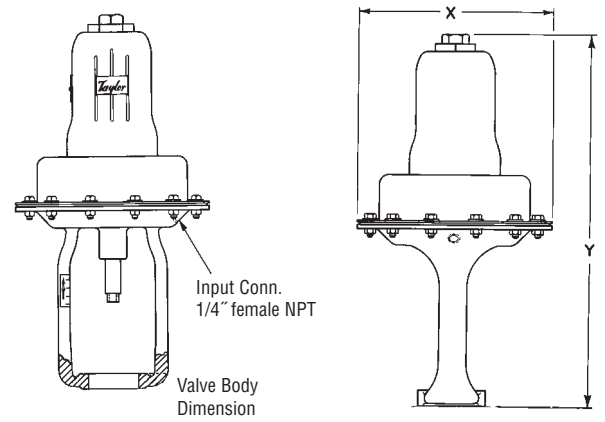

Figure 4. Mounting Dimension for Air-to-Raise Actuator
Standard Actuator in. (mm)

Term No.	Part No.	X	Y	No. of Bolts	Yoke Boss Hole Diam.
230	15S630	7-3/4 (196.85)	17-3/16 (436.56)	10	1-1/2 (38.10)
250	15S650	7-3/4 (196.85)	17-3/16 (436.56)	12	2-1/8 (53.98)
252	15S652	10-5/8 (269.86)	20-3/4 (527.05)	12	2-13/16 (71.44)
254	15S654	13-3/8 (339.73)	32-7/32 (818.36)	18	3-9/16 (90.49)

Senior Actuator in. (mm)

Term No.	Part No.	X	Y	No. of Bolts	Yoke Boss Hole Diam.
231	15S631	10-5/8 (269.86)	17-13/16 (452.44)	12	1-1/2 (38.10)
233	15S633	13-3/8 (339.73)	22-9/32 (565.94)	18	1-1/2 (38.10)
251	15S651	10-5/8 (269.86)	17-13/16 (452.44)	12	2-1/8 (53.98)
253	15S653	13-3/8 (339.73)	22-9/32 (565.94)	18	2-13/16 (71.44)

For reference only; not for construction.

3. OPERATION

3.1 Check Valve Travel - The actuator spring has been selected to meet the requirements of the application and has been adjusted at the factory to the pressure range stamped on the data plate. The spring has a constant rate of compression, and adjustments shift the pressure span up or down to make stem travel coincide with this pressure range. When in service, the actuator should yield the required travel when pressure range stamped on data plate is applied. This diaphragm pressure range is generally 3 to 15 psi (20 to 100 kPa), but other ranges may be used.

When the actuator is completely installed and connected to the control device, it should be checked with normal working line pressure conditions for correct travel. Apply the pressure range listed on the data plate to the actuator. Note that travel indicator should have moved the distance marked on indicator plate, Figure 5.

The pressure drop across the valve body ports has a direct effect on the actual operating pressure range. In some instances, the valve operating range may be different from the indicated range. This is because the pressure conditions in the valve body are different from those originally specified and for which the control valve has been set at the factory. If this difference is small, a spring adjustment is all that is required to obtain correct operating range, refer to Adjusting Actuator Range.

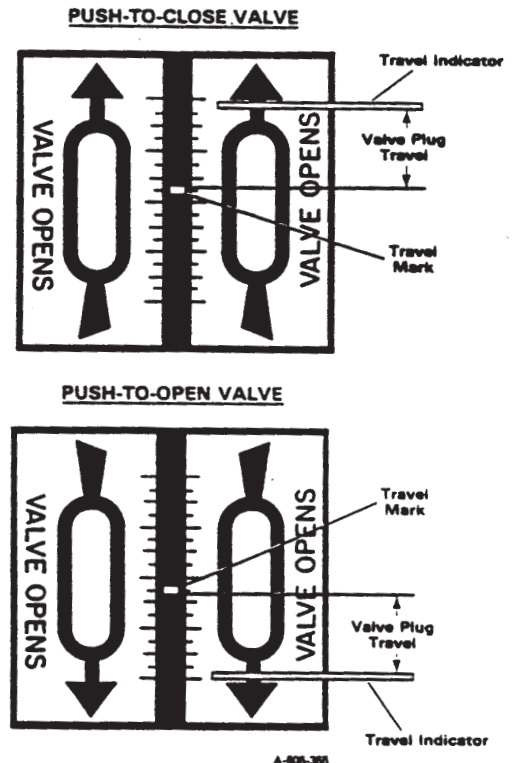

Figure 5. Travel Indicator Plate Showing Valve Plug Travel

3.2 Adjusting Actuator Range

Note: When using this procedure, be sure that the valve is operating under normal line pressure conditions.

3.2.1 Air-to-Lower Actuator

1. Slowly increase input pressure until stem just begins to move. Stem motion can be accurately detected by feeling stem or push rod as pressure is applied.

WARNING: If valve is used for steam service or where line process is hot, use visual means of detecting movement to avoid injury.

2. Note input pressure at which stem moves.

3. If input pressure is not the same as lower range value on data plate, spring adjusting screw must be adjusted.

If pressure is high, turn adjusting screw, Figure 6, counterclockwise as viewed from the valve top.

If pressure is low, turn adjusting screw clockwise as viewed from the valve top.

4. Release input pressure and repeat Steps 1, 2 and 3 until stem moves at the lower range value.

3.2.2 Air-to-Raise Actuator

1. Loosen the four set screws on travel stop collar, Figure 6, collar should move freely on push rod.

2. Slowly increase input pressure until stem just begins to move. Stem motion can be accurately detected by feeling stem or push rod as pressure is applied.

WARNING: If valve is used for steam service or where line process is hot, use visual means of detecting movement to avoid injury.

3. Note input pressure at which stem moves.

4. If input pressure is not the same as lower range value on data plate, spring adjusting screw must be adjusted.

If pressure is high, turn adjusting screw clockwise as viewed from the valve top.

If pressure is low, turn adjusting screw counterclockwise as viewed from the valve top.

5. Release input pressure and repeat Steps 2, 3 and 4 until valve stem moves at lower range value.

6. Apply the upper range value input pressure stamped on data plate. Slide travel stop collar up on push rod right to yoke and tighten the four set screws.

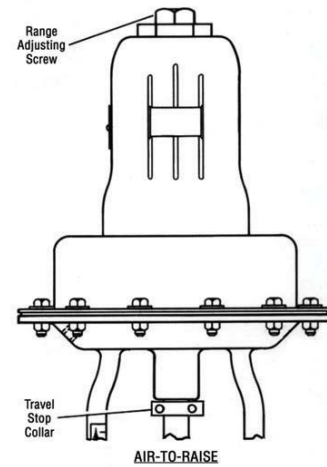
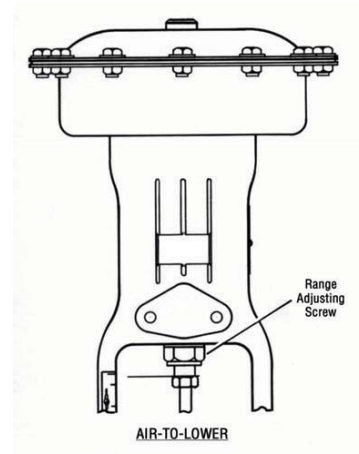

Figure 6. Adjusting Actuator Range

4. MAINTENANCE

4.1 Test Equipment and Tools Required - The only test equipment required for valve and actuator maintenance is an air supply source, gage and regulator. The tools required are shown in Table 4.

Table 4. Tools Required

Actuator Size	Tool	Size	Use
All	Screwdriver	3/16 in.	Travel Indicator Plate
		1/4 in.	
	Open End Wrenches	1/2 in.	Diaphragm Casing Mounting Screw & Nut
		9/16 in.	
		5/8 in.	
		7/8 in.	Range Spring Adjusting Screw
		1-1/4 in.	
	1-1/2 in.	Actuator Push Rod	
	1-15/16 in.		
	9/16 in.		
		11/16 in.	
		13/16 in.	
		31/32 in.	
		1 in.	

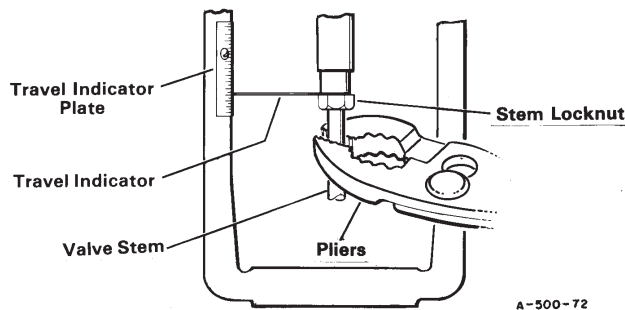

Figure 7. Adjusting Valve Plug Travel

4.2 Adjusting Valve Plug Travel - The purpose of this procedure is to adjust the length of valve stem engagement in the push rod so that the travel indicator is at the travel marks on the indicator plate when valve is fully closed.

4.2.1 Push-to-Close Valve with Air-to-Lower Actuator

1. Apply air pressure to actuator to fully close valve and note location of travel indicator.

2. If indicator is not at travel marks on plate, Figure 5, measure distance between indicator and mark.

CAUTION: Do not make any adjustments when valve plug is on its seat.

3. Vent all pressure from actuator.

4. Loosen stem locknut, Figure 7. Grip valve stem near threads, and turn stem to move valve plug the distance measured in Step 2.

5. Position indicator toward travel indicator plate and tighten valve stem locknut.

6. Repeat Steps 1 thru 5 until travel indicator is at travel marks when valve is fully closed.

Note: If pressure range required to obtain full valve plug travel does not agree with range stamped on data plate, refer to 3.2 Adjusting Actuator Range.

4.2.2 Push-to-Close Valve with Air-to-Raise Actuator or Push-to-Open Valve with Air-to-Lower Actuator

1. Apply air pressure to actuator to fully open valve and note location of travel indicator.

2. If indicator is not at travel marks on plate, Figure 5, measure distance between indicator and mark.

CAUTION: Do not make any adjustment when valve plug is on its seat.

3. Loosen stem locknut, Figure 7. Grip valve stem near threads, and turn stem to move valve plug the distance measured in Step 2.

4. Position indicator toward travel indicator plate and tighten valve stem locknut.

5. Vent all pressure from actuator.

6. Repeat Step 1 thru 5 until travel indicator is at travel marks when valve is fully opened.

Note: If pressure range required to obtain full valve plug travel does not agree with range stamped on data plate, refer to 3.2 Adjusting Actuator Range.

4.3 Replacing Actuator Diaphragm

WARNING: Before attempting any maintenance on control valve, make sure valve has been relieved of all pressure.

4.3.1 Air-to-Lower Actuator

1. Isolates or bypass the control valve in pipe line.

2. Shut off pressure to actuator and disconnect air line.

3. Turn range spring adjusting screw counter-clockwise to relieve all spring compression.

WARNING: If all spring compression is not relieved, serious injury can occur when removing upper diaphragm casing.

4. Loosen and remove all diaphragm casing mounting bolts, nuts and washer, Figure 8.

5. Lift off upper diaphragm casing from actuator assembly.

6. Remove old diaphragm and discard.

7. Install upper diaphragm casing with new diaphragm on actuator assembly. Fasten with bolts, nuts and washers removed in Step 4.

8. Reconnect pipe or tubing to pressure connection in upper diaphragm casing.

9. Readjust actuator travel, refer to 3.2 Adjusting Actuator Range.

4.3.2 Air-to-Raise Actuator

1. Isolate or bypass the control valve in pipe line.
2. Shut off pressure to actuator and disconnect air line.
3. Turn range spring adjusting screw clockwise to relieve all spring compression.

WARNING: If all spring compression is not relieved, serious injury can occur when removing spring and diaphragm casing.

4. Loosen and remove all diaphragm casing mounting bolts, nuts and washers, Figure 9.
5. Lift off spring and diaphragm casing from actuator assembly.
6. Remove old diaphragm and discard.
7. Install spring and diaphragm casing with new diaphragm on actuator assembly. Fasten with bolts, nuts and washers removed in Step 4.
8. Reconnect pipe or tubing to pressure connection in yoke.
9. Readjust actuator travel, refer to 3.2 Adjusting Actuator Range.

4.4 Changing Actuator Range Spring

4.4.1 Air-to-Lower Actuator

1. Isolate or bypass the control valve in pipe line.
2. Shut off pressure to actuator and disconnect air line.
3. Turn range spring adjusting screw counterclockwise to relieve all spring compression.

WARNING: If all spring compression is not relieved, serious injury can occur when removing upper diaphragm casing.

4. Loosen and remove all diaphragm casing mounting bolts, nuts and washer, Figure 8.
5. Lift off upper diaphragm casing and diaphragm from actuator assembly.
6. Loosen valve stem locknut just enough to unscrew push rod with push plate from valve stem.

CAUTION: Do not rotate valve plug on seat ring. It may be necessary to use pliers to hold valve stem. If necessary, grip stem near threads to avoid scoring stem.

7. Remove push rod and push plate with range spring from actuator assembly.
8. Install new range spring with push rod and push plate in actuator assembly.
9. Screw push rod on to valve stem on top of stem locknut and tighten locknut.
10. Install diaphragm casing with diaphragm on actuator assembly. Fasten with the bolts, nuts and washers removed in Step 4.
11. Reconnect pipe or tubing to pressure connection in upper diaphragm casing.
12. Readjust actuator travel, refer to 3.2 Adjusting Actuator Range.

4.4.2 Air-to-Raise Actuator

1. Isolate or bypass the control valve in pipe line.
2. Shut off pressure to actuator and disconnect air line.
3. Turn range spring adjusting screw clockwise to relieve all spring compression.

WARNING: If all spring compression is not relieved, serious injury can occur when removing spring casing.

4. Unscrew spring casing with adjusting screw from diaphragm casing, Figure 9.
5. Remove old range spring and install new spring.
6. Screw spring casing with adjusting screw onto diaphragm casing.
7. Reconnect pipe or tubing to pressure connection in yoke.
8. Readjust actuator travel, refer to 3.2 Adjusting Actuator Range.

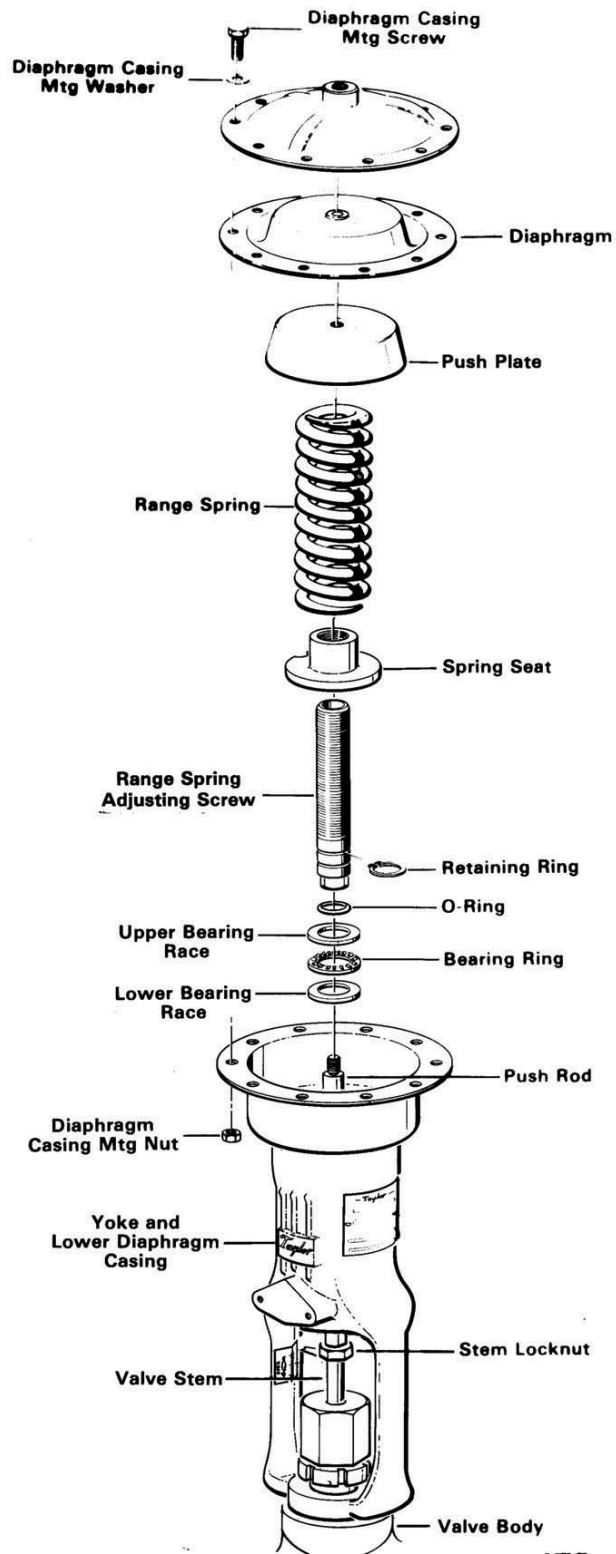

Figure 8. Disassembly of Air-to-Lower Actuator

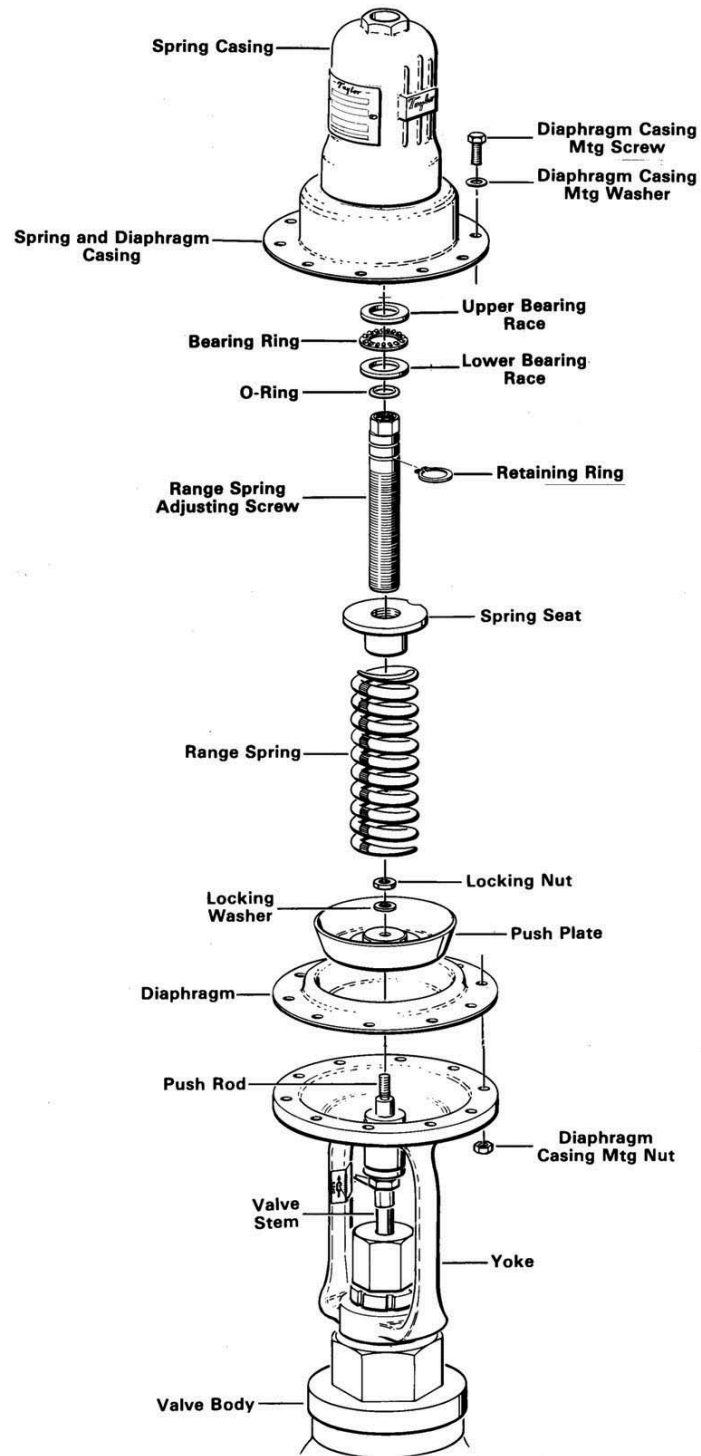

Figure 9. Disassembly of Air-to-Raise Actuator

NOTES:
