

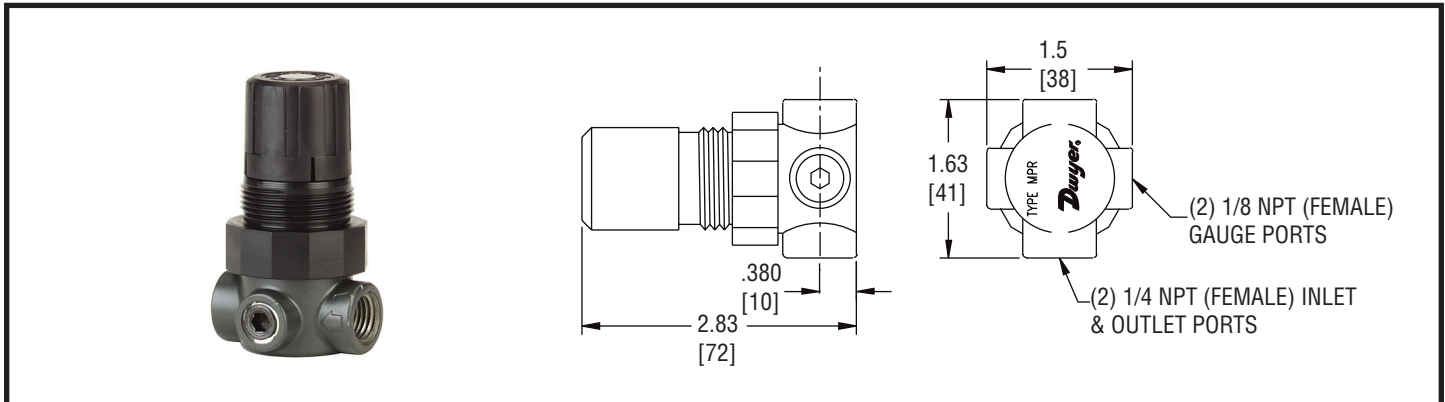

Series MPR Miniature Pressure Regulator

Specifications-Installation and Operating Instructions



DESCRIPTION

The Series MPR Miniature Pressure Regulators are compact units that provide low cost, high performance pressure regulation of compressed air or water. The low torque, non-rising adjustment knob with locking capability provides easy and precise regulation and prevents leakage. The compact size and lightweight construction make this unit ideal for the OEM market and portable equipment including adhesive dispensers, printing presses, medical equipment, spray equipment, analyzers, pumps, compressors, welding machines and many more. Model MPR1 is a relieving regulator and model MPR2 is a non-relieving regulator. (The MPR2 is typically used in water applications). When controlling air, Series MPR should be used in constant flow or downstream pressure relief applications.

INSTALLATION

1. System piping should be the same pipe size as regulator ports. Locate regulator as close as possible to the device using regulated air. If cycling devices and /or lubricators are used in the piping system, install the regulator upstream of these devices. A filter installed upstream of the regulator is recommended to maximize service life.
2. **The arrow on the regulator body indicates direction of air flow.** Connect piping to proper ports using pipe sealant on male threads only. Do not allow sealant to enter interior of regulator. The Series MPR can be installed at any angle.
3. Two 1/8" NPT gauge ports are provided to allow for the connection of an outlet pressure gauge or as additional outlets for regulated air. Plug unused gauge ports. Panel-mounted units require a 1 3/16" (6.350 mm) diameter hole with a maximum panel thickness of 1/4" (4.8 mm).

PHYSICAL DATA

Service: Compressed air or water.

Port Size: Inlet or outlet: Two 1/4" NPT (Female);
Two 1/8" NPT (Female) gauge ports.

Maximum Supply Pressure: 250 psig (17.2 bar).

Flow Capacity: 24 SCFM (48 m³/hr) at 100 psig (6.9 bar) supply, 60 psig (4.1 bar) output.

Operating Temperature: 0 to 150°F (-18 to 60°C).

Materials: Body: Zinc; Bonnet: Acetal;
Diaphragm/Seals: Nitrile; Internals: Aluminum, brass, acetal, steel, music wire (MPR is plated with electroless nickel for water use).

Weight: 4 oz. (113 g).

ADJUSTMENT

1. Pull the knob outward to unlock and adjust pressure setting. Before turning on system air pressure, turn regulator knob counter-clockwise just until the knob stops. Turn on system air pressure. Turn regulator knob clockwise until outlet pressure reaches desired setting.
2. When changing pressure setting, always approach the desired pressure from a lower setting. For example, lowering the outlet pressure from 80 psi to 60 psi is best accomplished by dropping the outlet pressure to 50 psi, and then adjusting up to 60 psi.
3. Push knob inward to lock pressure setting.

DWYER INSTRUMENTS, INC.

P.O. BOX 373 • MICHIGAN CITY, INDIANA 46361, U.S.A.

Phone: 219/879-8000

Fax: 219/872-9057

Lit-By Fax: 888/891-4963

www.dwyer-inst.com

e-mail: info@dwyer-inst.com

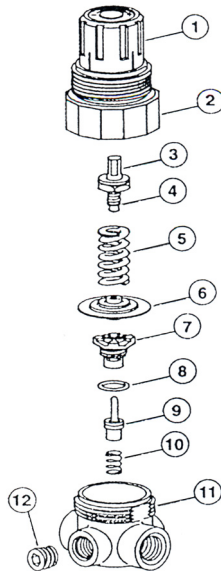

No.	Part Description	Material
1	Knob	Acetal
2	Bonnet	Acetal
3	Adjusting Screw	Zinc-Plated Steel
4	Adjusting Nut	Zinc-Plated Steel
5	Range Spring	Zinc-Plated Steel
6	Diaphragm Assembly	Acetal/Nitrile
7	Supply Seat	Acetal
8	Supply Seat O-Ring	Nitrile
9	Pintle	Aluminum/Nitrile
10	Pintle Spring	300 Stainless Steel
11	Body	Zinc Alloy
12	Pipe Plugs	Steel

MAINTENANCE

WARNING: Air supply pressure must be shut off before attempting to install or disassemble regulator for servicing.

- If air supply is kept clean, regulator should provide long periods of uninterrupted service. If erratic performance occurs, it is likely that parts in the regulator need to be cleaned or replaced.
- TO DISASSEMBLE:** **Reduce pressure in inlet and outlet lines to zero. Regulator can be serviced without removal from line.** Pull knob out to disengage lock and turn knob counter-clockwise until it stops. This will remove any load on the range spring. Unscrew bonnet. Adjusting screw and nut are not retained, and may fall out. Remove range spring and diaphragm assembly. Unscrew supply seat (hex socket size is $\frac{9}{16}$ "), and remove pintle and pintle spring.
- CLEANING:** Clean parts in warm water and mild soap and let air dry. Using dry, clean compressed air, blow out the body. If any parts are damaged, consult the

factory for an RGA (Returned Goods Authorization) Number.

- TO REASSEMBLE:** Lubricate O-ring on supply seat with quality O-ring grease. Tighten supply seat into body of regulator. Make sure the pintle slides up and down freely after tightening supply seat. Tighten bonnet onto body. **Do not over tighten, as it could strip bonnet threads.**

WARNING

- The Series MPR Miniature Pressure Regulators are intended for use in industrial compressed air system only. Do not use where pressure and temperatures can exceed those listed under **PHYSICAL DATA** in this manual.
- In relieving-type regulators (MPR1), excess pressure is vented out of the regulator when there is an increase in downstream pressure above the pressure setting. However, relief capacity is limited. If a sudden increase in downstream pressure could rupture or malfunction downstream equipment, install a pressure-relief device downstream of the regulator. The capacity of the relief device must satisfy the system requirements.
- In non-relieving regulators (MPR2), downstream pressure above the pressure setting does not relieve to atmosphere. Another means of relieving pressure must be provided, if necessary.
- Before using these products with anything other than air or the specified fluids, for non-industrial applications, life-support systems, or other applications not within published specifications, please consult the factory.

MAINTENANCE/REPAIR

The Series MPR2 Miniature Pressure Regulator is warranted to be free from defects for one year from date of invoice. All warranty repairs or credit are determined upon inspection at the factory. For the best service, please obtain a Returned Goods Authorization (RGA) number, send the material, freight prepaid, to the following address. Please include a clear description of the problem plus any application information available.

Dwyer Instruments
 Attn: Repair Department
 102 Highway 212
 Michigan City, IN 46360