

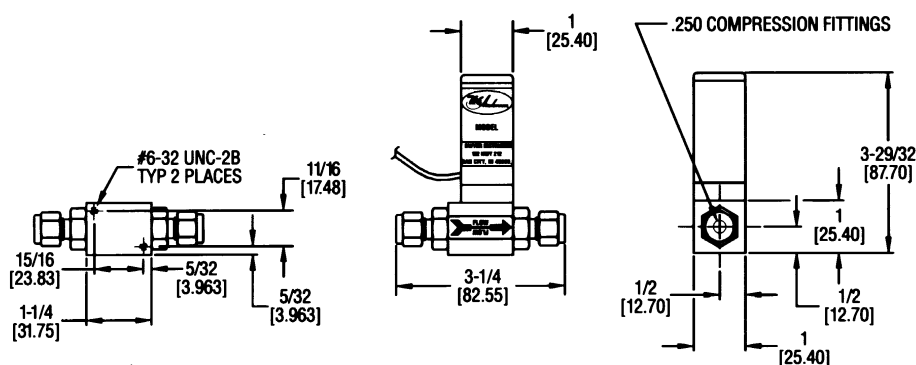

Series SVP Proportioning Solenoid Valve

Specifications - Installation and Operating Instructions



The SVP Series is a low cost, uniquely designed solenoid valve which controls or regulates flow in proportion to a variable voltage input. While most solenoid valves simply provide on/off service, this unit adds a totally new dimension to solenoid valve performance. Reacting to a 0-24 VDC input signal, the valve opens proportional to the voltage applied, delivering just the right amount of flow needed. Compatible with a wide range of gases and liquids, this unit provides the solution to even the most demanding applications like process control, chemical mixing, high tech manufacturing and laboratory testing. Another quality feature of this valve is its tight shut-off (NC) when de-energized.

Stocked Models:

| Model No. | Orifice IN. (MM) | C _v | Maximum Flow* | |
|-----------|------------------|----------------|----------------|------------------|
| | | | Air SCFH (LPM) | Water GPH (CC/M) |
| SVP-1 | 0.020 (0.51) | 0.009 | 7.4 (3.5) | 2.0 (125) |
| SVP-2 | 0.040 (1.02) | 0.033 | 27.5 (13) | 6.4 (400) |
| SVP-3 | 0.055 (1.40) | 0.055 | 45.6 (21.5) | 11.1 (700) |
| SVP-4 | 0.063 (1.60) | 0.068 | 53 (25) | 13.5 (850) |

*Based on 10 psig (69 kPa) inlet pressure and atmospheric exhaust.

INSTALLATION

Select a location which is free of excessive heat, moisture and vibration. The series SVP Proportioning Solenoid Valve may be held in place by your 1/4" metal process tubing or secured to a rigid surface via the two 6-32 tapped holes in the base of the valve body. Flow through the valve should be in the direction of the arrow marked on the body. The Series SVP Valve may be used with most gases or liquids that are compatible with the wetted parts: 316 and 416 stainless steel and Viton®. Due to the small orifice size of the Series SVP, the media must be free of scale, particulate, or any other contaminant's which might interfere with the motion of the valve.

PHYSICAL DATA

Voltage Input: 0-24 VDC.

Maximum Operating Current: 400 mA.

Electrical Connections: Male spade type.

Wetted Materials: 316 and 416 stainless steel, Viton®, O-rings.

Maximum Pressure: 500 psig (34.45 bar).

Process Temperature Limits: -40°F to 174°F (-40°C to 79°C).

Ambient Temperature Limits: -40°F to 130°F (-40°C to 54°C).

Type of Operation: Normally closed, valve will close when de-energized.

Connections: 1/4" compression fitting.

Weight: 12 oz. (340 grams).

The precise flow characteristics of each valve will vary depending on a number of factors, including orifice size and upstream pressure. While it is best to determine valve performance under your own process conditions, the flow curve shown in Fig. A can be used for reference purposes.

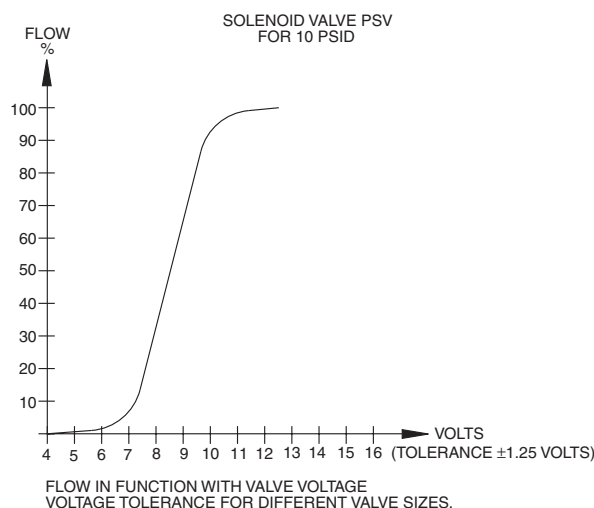

Fig. A